



## Ultra-Small, Low-Power, SPI™-Compatible, 16-Bit Analog-to-Digital Converter and Temperature Sensor with Internal Reference

Check for Samples: [ADS1118](#)

### FEATURES

- **Ultra-Small QFN Package:**  
2mm × 1,5mm × 0,4mm
- **Wide Supply Range: 2.0V to 5.5V**
- **Low Current Consumption:**
  - **Continuous Mode: Only 150µA**
  - **Single-Shot Mode: Auto Shutdown**
- **Programmable Data Rate:**  
8SPS to 860SPS
- **Single-Cycle Settling**
- **Internal Low-Drift Voltage Reference**
- **Internal Temperature Sensor:**
  - **0.5°C Max Error**
- **Internal Oscillator**
- **Internal PGA**
- **Four Single-Ended or Two Differential Inputs**

### APPLICATIONS

- **Temperature Measurement:**
  - **Thermocouple Measurement**
  - **Cold Junction Compensation**
  - **Thermistor Measurement**
- **Portable Instrumentation**
- **Factory Automation and Process Controls**

### DESCRIPTION

The ADS1118 is a precision analog-to-digital converter (ADC) with 16 bits of resolution offered in an ultra-small, leadless QFN-10 package or an MSOP-10 package. The ADS1118 is designed with precision, power, and ease of implementation in mind. The ADS1118 features an onboard reference and oscillator. Data are transferred via a serial peripheral interface (SPI). The ADS1118 operates from a single power supply ranging from 2V to 5.5V.

The ADS1118 can perform conversions at rates up to 860 samples per second (SPS). An onboard programmable gain amplifier (PGA) is available on the ADS1118 that offers input ranges from the supply to as low as ±256mV. This range allows both large and small signals to be measured with high resolution. The ADS1118 also features an input multiplexer (MUX) that provides two differential or four single-ended inputs. The ADS1118 can also function as a high-accuracy temperature sensor. This temperature sensor can be used for system-level temperature monitoring or cold junction compensation for thermocouples.

The ADS1118 operates either in continuous conversion mode or a single-shot mode that automatically powers down after a conversion. Single-shot mode significantly reduces current consumption during idle periods. The ADS1118 is specified from –40°C to +125°C.

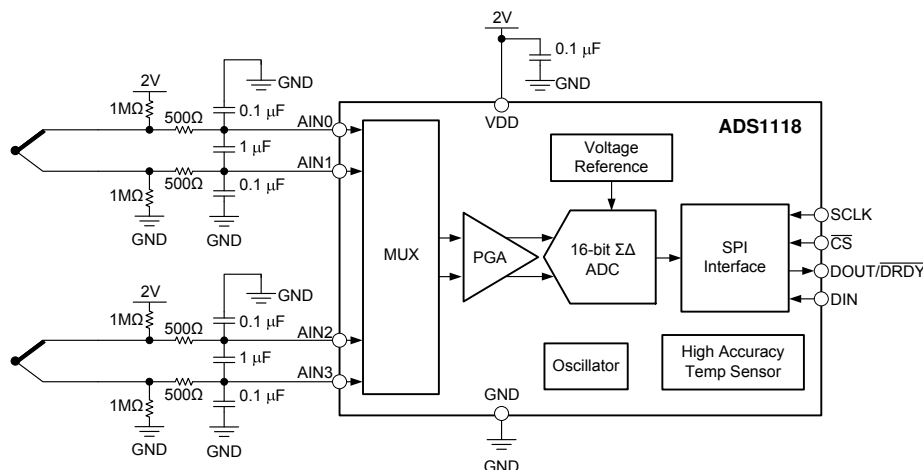

Please be aware that an important notice concerning availability, standard warranty, and use in critical applications of Texas Instruments semiconductor products and disclaimers thereto appears at the end of this data sheet.

SPI is a trademark of Motorola.

All other trademarks are the property of their respective owners.



This integrated circuit can be damaged by ESD. Texas Instruments recommends that all integrated circuits be handled with appropriate precautions. Failure to observe proper handling and installation procedures can cause damage.

ESD damage can range from subtle performance degradation to complete device failure. Precision integrated circuits may be more susceptible to damage because very small parametric changes could cause the device not to meet its published specifications.

### ORDERING INFORMATION

For the most current package and ordering information, see the Package Option Addendum at the end of this document, or visit the device product folder on [www.ti.com](http://www.ti.com).

### ABSOLUTE MAXIMUM RATINGS<sup>(1)</sup>

		ADS1118	UNIT
VDD to GND		−0.3 to +5.5	V
Analog input current		100, momentary	mA
Analog input current		10, continuous	mA
Analog input voltage to GND		−0.3 to VDD + 0.3	V
DIN, DOUT/ $\overline{\text{DRDY}}$ , SCLK, $\overline{\text{CS}}$ voltage to GND		−0.3 to +5.5	V
ESD ratings	Human body model (HBM) JEDEC standard 22, test method A114-C.01, all pins	±4000	V
	Charged device model (CDM) JEDEC standard 22, test method C101, all pins	±1000	V
Operating temperature range		−40 to +125	°C
Maximum junction temperature		+150	°C
Storage temperature range		−60 to +150	°C

(1) Stresses above those listed under *Absolute Maximum Ratings* may cause permanent damage to the device. Exposure to absolute maximum conditions for extended periods may affect device reliability.

### PRODUCT FAMILY

DEVICE	RESOLUTION (Bits)	MAXIMUM SAMPLE RATE (SPS)	SPECIAL FEATURES	PGA	INTERFACE	INPUT CHANNELS (Differential/Single-Ended)
<a href="#">ADS1118</a>	16	860	Temperature sensor	Yes	SPI	2/4
<a href="#">ADS1018</a>	12	3300	Temperature sensor	Yes	SPI	2/4
<a href="#">ADS1115</a>	16	860	Comparator	Yes	I <sup>2</sup> C	2/4
<a href="#">ADS1114</a>	16	860	Comparator	Yes	I <sup>2</sup> C	1/1
<a href="#">ADS1113</a>	16	860	None	No	I <sup>2</sup> C	1/1
<a href="#">ADS1015</a>	12	3300	Comparator	Yes	I <sup>2</sup> C	2/4
<a href="#">ADS1014</a>	12	3300	Comparator	Yes	I <sup>2</sup> C	1/1
<a href="#">ADS1013</a>	12	3300	None	No	I <sup>2</sup> C	1/1

## ELECTRICAL CHARACTERISTICS

Maximum/minimum specifications at  $-40^{\circ}\text{C}$  to  $+125^{\circ}\text{C}$ ,  $V_{\text{DD}} = 3.3\text{V}$ , data rate = 8SPS, and full-scale (FS) =  $\pm 2.048\text{V}$ , unless otherwise noted. Typical values are at  $+25^{\circ}\text{C}$ ,  $V_{\text{DD}} = 3.3\text{V}$ , data rate = 8SPS, and full-scale (FS) =  $\pm 2.048\text{V}$ , unless otherwise noted.

PARAMETER	TEST CONDITIONS	ADS1118			UNIT
		MIN	TYP	MAX	
<b>ANALOG INPUT</b>					
Full-scale input voltage <sup>(1)</sup>	$V_{\text{IN}} = (\text{AIN}_{\text{P}}) - (\text{AIN}_{\text{N}})$		$\pm 4.096/\text{PGA}$		V
Analog input voltage	$\text{AIN}_{\text{P}}$ or $\text{AIN}_{\text{N}}$ to GND	GND		$V_{\text{DD}}$	V
Differential input impedance			See <a href="#">Table 1</a>		
Common-mode input impedance	$\text{FS} = \pm 6.144\text{V}^{(1)}$		8		$\text{M}\Omega$
	$\text{FS} = \pm 4.096\text{V}^{(1)}, \pm 2.048\text{V}$		6		$\text{M}\Omega$
	$\text{FS} = \pm 1.024\text{V}$		3		$\text{M}\Omega$
	$\text{FS} = \pm 0.512\text{V}, \pm 0.256\text{V}$		100		$\text{M}\Omega$
<b>SYSTEM PERFORMANCE</b>					
Resolution	No missing codes	16			Bits
Data rate (DR)		8, 16, 32, 64, 128, 250, 475, 860			SPS
Data rate variation	All data rates	-10		10	%
Output noise		See <a href="#">Typical Characteristics</a>			
Integral nonlinearity	$\text{DR} = 8\text{SPS}, \text{FS} = \pm 2.048\text{V}$ , best fit <sup>(2)</sup>			1	LSB
Offset error	$\text{FS} = \pm 2.048\text{V}$ , differential inputs		$\pm 0.1$	$\pm 2$	LSB
	$\text{FS} = \pm 2.048\text{V}$ , single-ended inputs		$\pm 0.25$		LSB
Offset drift	$\text{FS} = \pm 2.048\text{V}$		0.002		LSB/ $^{\circ}\text{C}$
Offset power-supply rejection	$\text{FS} = \pm 2.048\text{V}$ , with dc supply variation		0.2		LSB/V
Gain error <sup>(3)</sup>	$\text{FS} = \pm 2.048\text{V}$ at $+25^{\circ}\text{C}$		0.01	0.15	%
Gain drift <sup>(3)(4)</sup>	$\text{FS} = \pm 0.256\text{V}$		7		ppm/ $^{\circ}\text{C}$
	$\text{FS} = \pm 2.048\text{V}$		5	40	ppm/ $^{\circ}\text{C}$
	$\text{FS} = \pm 6.144\text{V}^{(1)}$		5		ppm/ $^{\circ}\text{C}$
Gain power-supply rejection			10		ppm/V
PGA gain match <sup>(3)</sup>	Match between any two PGA gains		0.01	0.1	%
Gain match	Match between any two inputs		0.01	0.1	%
Offset match	Match between any two inputs		0.6		LSB
Common-mode rejection	At dc and $\text{FS} = \pm 0.256\text{V}$		105		dB
	At dc and $\text{FS} = \pm 2.048\text{V}$		100		dB
	At dc and $\text{FS} = \pm 6.144\text{V}^{(1)}$		90		dB
	$f_{\text{CM}} = 60\text{Hz}$ , $\text{DR} = 860\text{SPS}$		105		dB
	$f_{\text{CM}} = 50\text{Hz}$ , $\text{DR} = 860\text{SPS}$		105		dB
<b>TEMPERATURE SENSOR</b>					
Temperature sensor range		-40		+125	$^{\circ}\text{C}$
Temperature sensor resolution			0.03125		$^{\circ}\text{C}/\text{LSB}$
Temperature sensor accuracy	$0^{\circ}\text{C}$ to $+70^{\circ}\text{C}$		0.2	$\pm 0.5$	$^{\circ}\text{C}$
	$-40^{\circ}\text{C}$ to $+125^{\circ}\text{C}$		0.4	$\pm 1$	$^{\circ}\text{C}$
	vs supply		0.03125	$\pm 0.25$	$^{\circ}\text{C}/\text{V}$

(1) This parameter expresses the full-scale range of the ADC scaling. In no event should more than the smaller of  $V_{\text{DD}} + 0.3\text{V}$  or  $5.5\text{V}$  be applied to this device.

(2) Best fit INL covers 99% of full-scale.

(3) Includes all errors from onboard PGA and reference.

(4) Not production tested; ensured by characterization.

## ELECTRICAL CHARACTERISTICS (continued)

Maximum/minimum specifications at  $-40^{\circ}\text{C}$  to  $+125^{\circ}\text{C}$ ,  $V_{\text{DD}} = 3.3\text{V}$ , data rate = 8SPS, and full-scale (FS) =  $\pm 2.048\text{V}$ , unless otherwise noted. Typical values are at  $+25^{\circ}\text{C}$ ,  $V_{\text{DD}} = 3.3\text{V}$ , data rate = 8SPS, and full-scale (FS) =  $\pm 2.048\text{V}$ , unless otherwise noted.

PARAMETER	TEST CONDITIONS	ADS1118			UNIT
		MIN	TYP	MAX	
<b>DIGITAL INPUT/OUTPUT</b>					
Logic level					
$V_{\text{IH}}$		0.7VDD		VDD	V
$V_{\text{IL}}$		GND		0.2VDD	V
$V_{\text{OH}}$	$I_{\text{OH}} = 1\text{mA}$	0.8VDD			V
$V_{\text{OL}}$	$I_{\text{OL}} = 1\text{mA}$	GND		0.2VDD	V
Input leakage					
$I_{\text{H}}$	$V_{\text{IH}} = 5.5\text{V}$			$\pm 10$	$\mu\text{A}$
$I_{\text{L}}$	$V_{\text{IL}} = \text{GND}$			$\pm 10$	$\mu\text{A}$
<b>POWER-SUPPLY REQUIREMENTS</b>					
Power-supply voltage		2		5.5	V
Supply current	Power-down current at $+25^{\circ}\text{C}$		0.5	2	$\mu\text{A}$
	Power-down current up to $+125^{\circ}\text{C}$			5	$\mu\text{A}$
	Operating current at $+25^{\circ}\text{C}$		150	200	$\mu\text{A}$
	Operating current up to $+125^{\circ}\text{C}$			300	$\mu\text{A}$
Power dissipation	$V_{\text{DD}} = 5.0\text{V}$		0.9		mW
	$V_{\text{DD}} = 3.3\text{V}$		0.5		mW
	$V_{\text{DD}} = 2.0\text{V}$		0.3		mW
<b>TEMPERATURE</b>					
Storage temperature		$-60$		$+150$	$^{\circ}\text{C}$
Specified temperature		$-40$		$+125$	$^{\circ}\text{C}$

## THERMAL INFORMATION

THERMAL METRIC <sup>(1)</sup>		ADS1118	UNITS
		DGS	
		10 PINS	
$\theta_{\text{JA}}$	Junction-to-ambient thermal resistance	186.8	$^{\circ}\text{C}/\text{W}$
$\theta_{\text{JCTop}}$	Junction-to-case (top) thermal resistance	51.5	
$\theta_{\text{JB}}$	Junction-to-board thermal resistance	108.4	
$\psi_{\text{JT}}$	Junction-to-top characterization parameter	2.7	
$\psi_{\text{JB}}$	Junction-to-board characterization parameter	106.5	
$\theta_{\text{JCbott}}$	Junction-to-case (bottom) thermal resistance	n/a	

(1) For more information about traditional and new thermal metrics, see the *IC Package Thermal Metrics* application report, [SPRA953](#).

## PIN CONFIGURATIONS

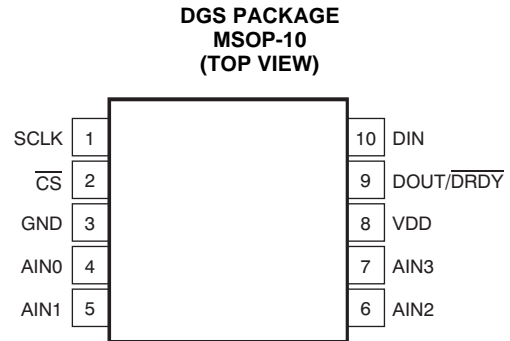
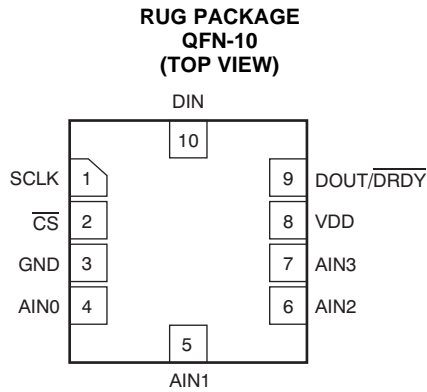

## PIN DESCRIPTIONS

PIN #	PIN NAME	ANALOG/ DIGITAL INPUT/ OUTPUT	DESCRIPTION
1	SCLK	Digital input	Serial clock input
2	$\overline{\text{CS}}$	Digital input	Chip select; active low
3	GND	Analog	Ground
4	AIN0	Analog input	Differential channel 1: positive input or single-ended channel 1 input
5	AIN1	Analog input	Differential channel 1: negative input or single-ended channel 2 input
6	AIN2	Analog input	Differential channel 2: positive input or single-ended channel 3 input
7	AIN3	Analog input	Differential channel 2: negative input or single-ended channel 4 input
8	VDD	Analog	Power supply: 2V to 5.5V
9	DOUT/ $\overline{\text{DRDY}}$	Digital output	Serial data out combined with data ready; active low
10	DIN	Digital input	Serial data input

### SPI TIMING CHARACTERISTICS

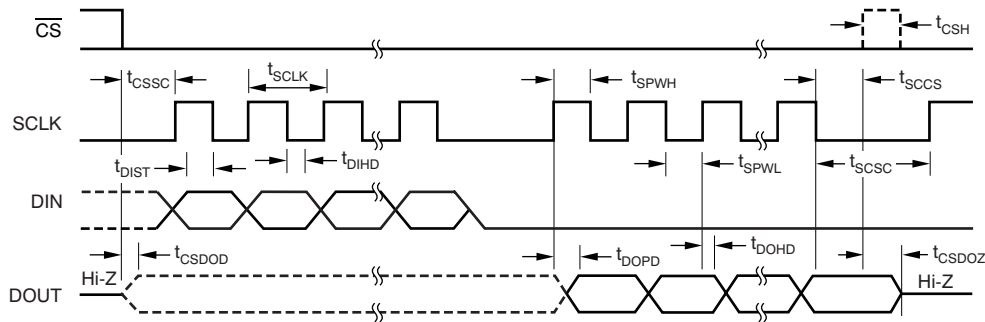

Figure 1. Serial Interface Timing

### TIMING REQUIREMENTS: SERIAL INTERFACE TIMING

At  $T_A = -40^\circ\text{C}$  to  $+125^\circ\text{C}$  and  $V_{DD} = 2\text{V}$  to  $5.5\text{V}$ , unless otherwise noted.

SYMBOL	DESCRIPTION	MIN	MAX	UNIT
$t_{CSSC}$	$\overline{CS}$ low to first SCLK: setup time <sup>(1)</sup>	100		ns
$t_{SCLK}$	SCLK period	250		ns
$t_{SPWH}$	SCLK pulse width: high	100		ns
$t_{SPWL}$	SCLK pulse width: low <sup>(2)</sup>	100		ns
			28	ms
$t_{DIST}$	Valid DIN to SCLK falling edge: setup time	50		ns
$t_{DIHD}$	Valid DIN to SCLK falling edge: hold time	50		ns
$t_{DOPD}$	SCLK rising edge to valid new DOUT: propagation delay <sup>(3)</sup>		50	ns
$t_{DOHD}$	SCLK rising edge to DOUT invalid: hold time	0		ns
$t_{CSDOD}$	$\overline{CS}$ low to DOUT driven: propagation delay	100		ns
$t_{CSDOZ}$	$\overline{CS}$ high to DOUT Hi-Z: propagation delay	100		ns
$t_{CSH}$	$\overline{CS}$ high pulse	200		ns
$t_{SCCS}$	Final SCLK falling edge to $\overline{CS}$ high	100		ns

- (1)  $\overline{CS}$  can be tied low.
- (2) Holding SCLK low longer than 28ms resets the SPI interface.
- (3) DOUT load = 20pF || 100kΩ to DGND.

**TYPICAL CHARACTERISTICS**

At  $T_A = +25^\circ\text{C}$  and  $V_{DD} = 3.3\text{V}$ , unless otherwise noted.

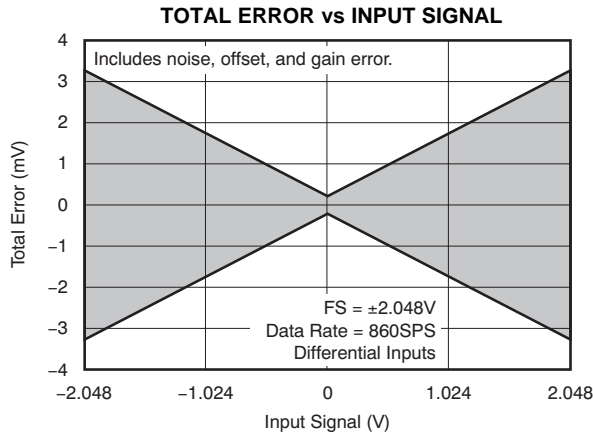

Figure 2.

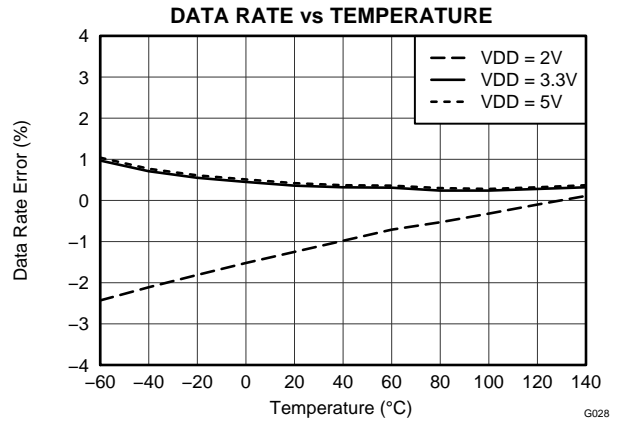

Figure 3.

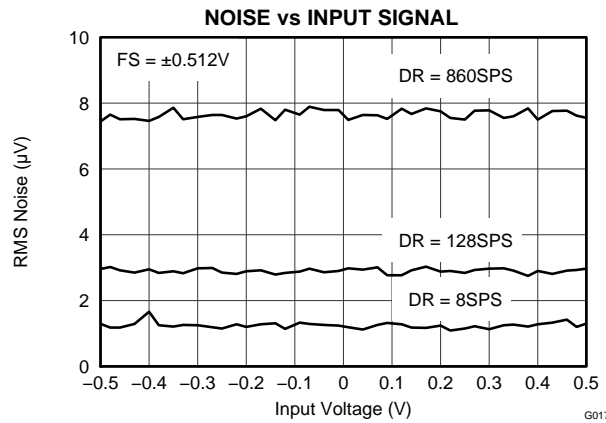

Figure 4.

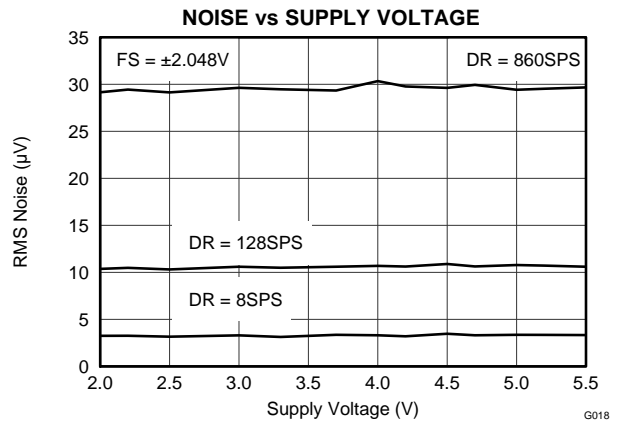

Figure 5.

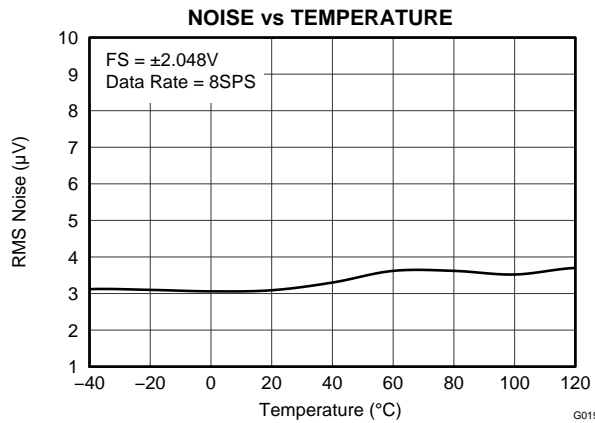

Figure 6.

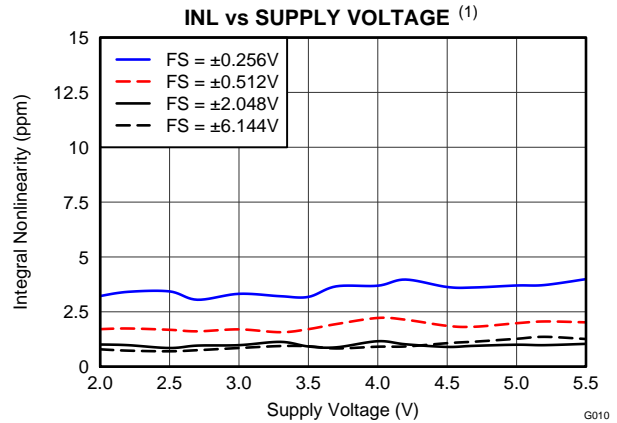

Figure 7.

(1) This parameter expresses the full-scale range of the ADC scaling. In no event should more than  $V_{DD} + 0.3\text{V}$  be applied to this device.

**TYPICAL CHARACTERISTICS (continued)**

At  $T_A = +25^\circ\text{C}$  and  $V_{DD} = 3.3\text{V}$ , unless otherwise noted.

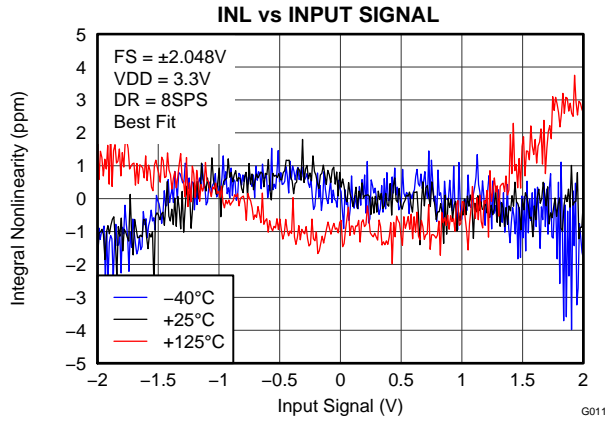

Figure 8.

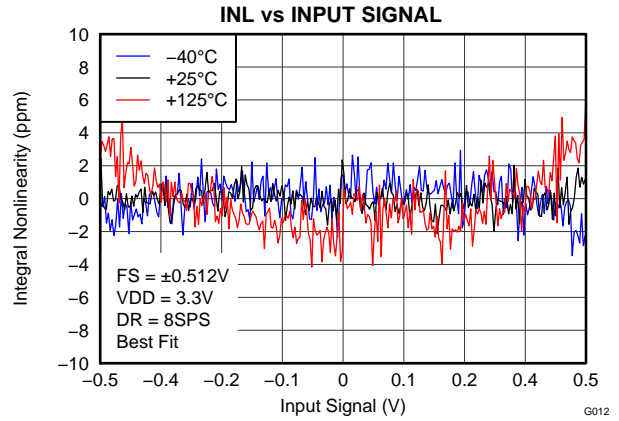

Figure 9.

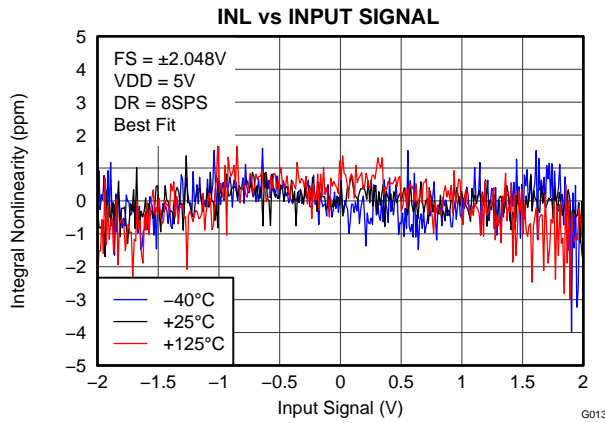

Figure 10.

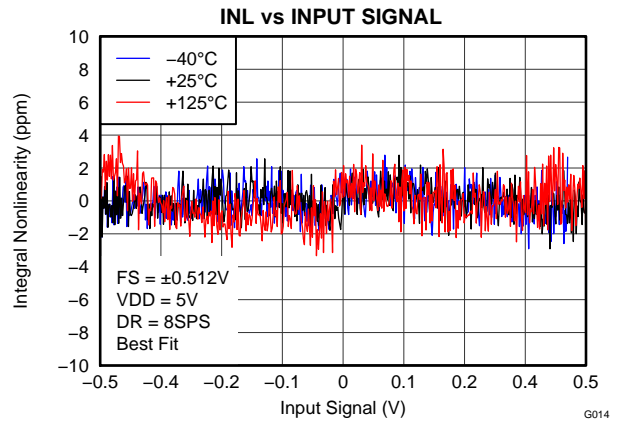

Figure 11.

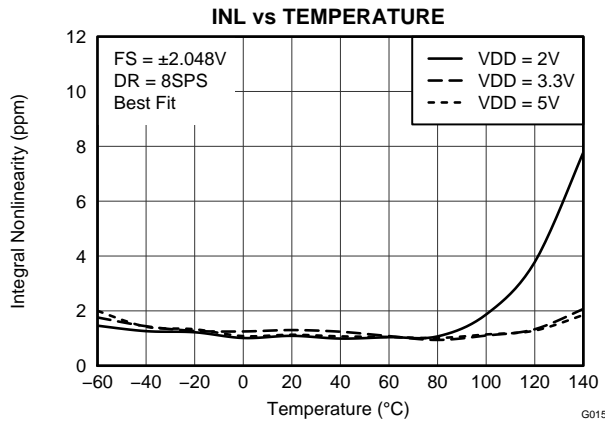

Figure 12.

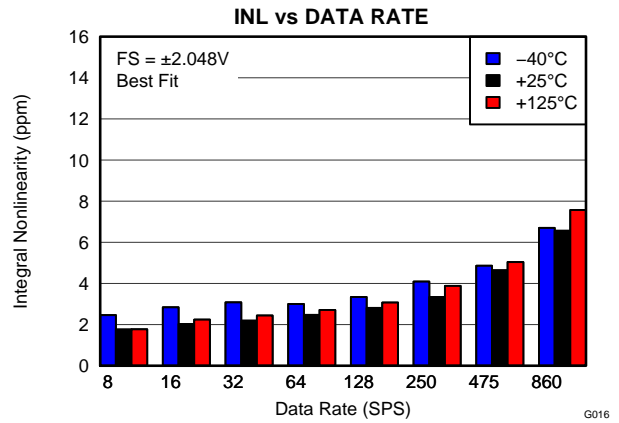

Figure 13.



TYPICAL CHARACTERISTICS (continued)

At  $T_A = +25^\circ\text{C}$  and  $V_{DD} = 3.3\text{V}$ , unless otherwise noted.

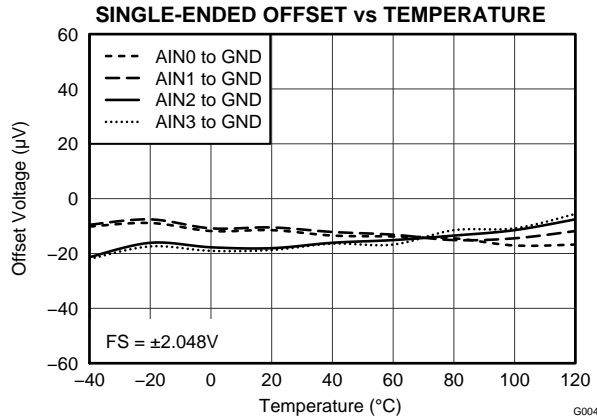

Figure 14.

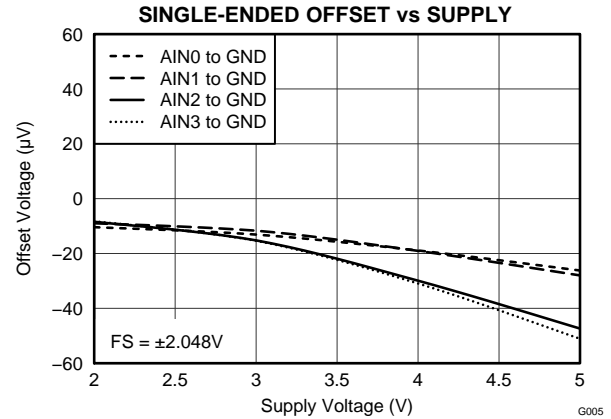

Figure 15.

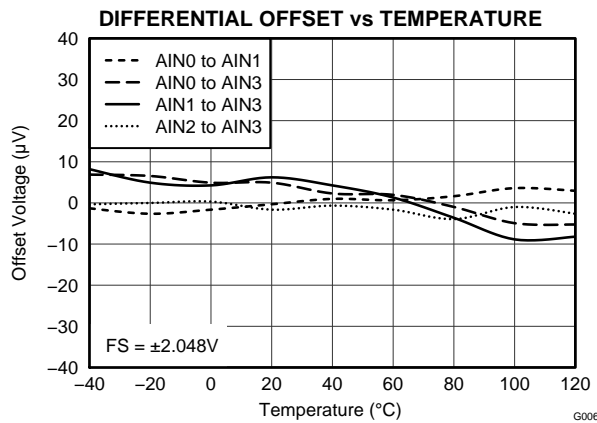

Figure 16.

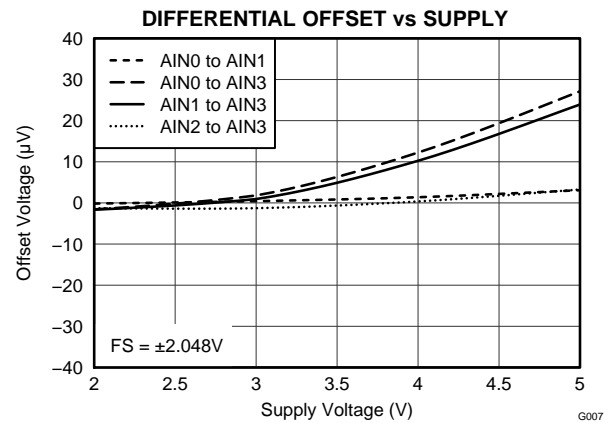

Figure 17.

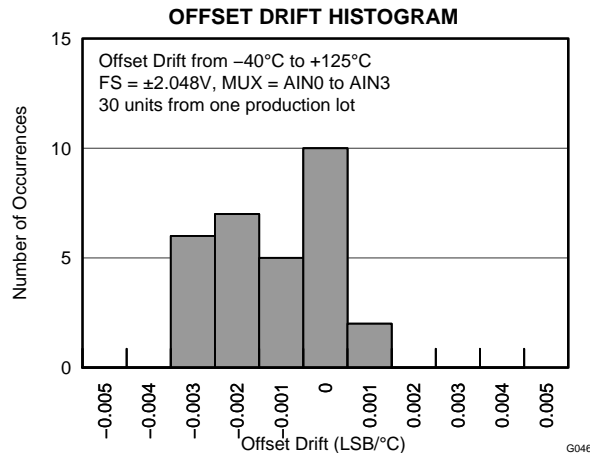

Figure 18.

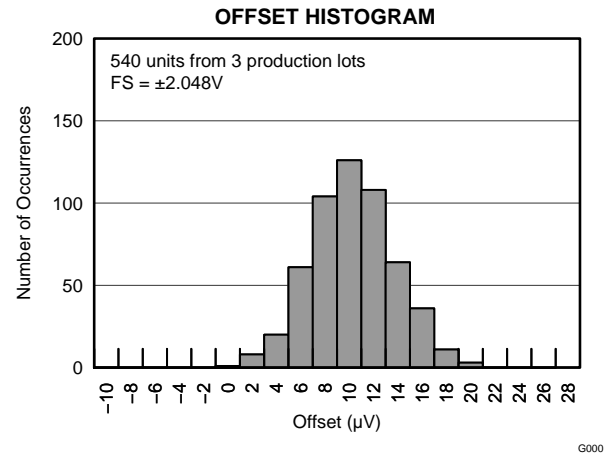

Figure 19.

**TYPICAL CHARACTERISTICS (continued)**

At  $T_A = +25^\circ\text{C}$  and  $V_{DD} = 3.3\text{V}$ , unless otherwise noted.

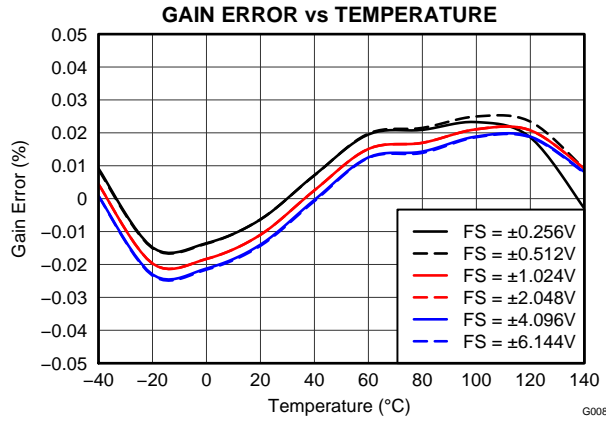

Figure 20.

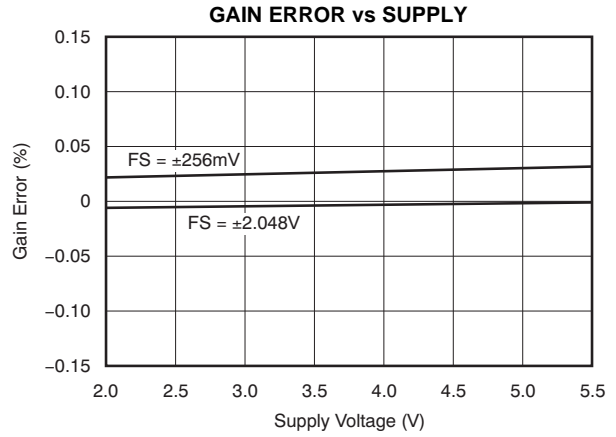

Figure 21.

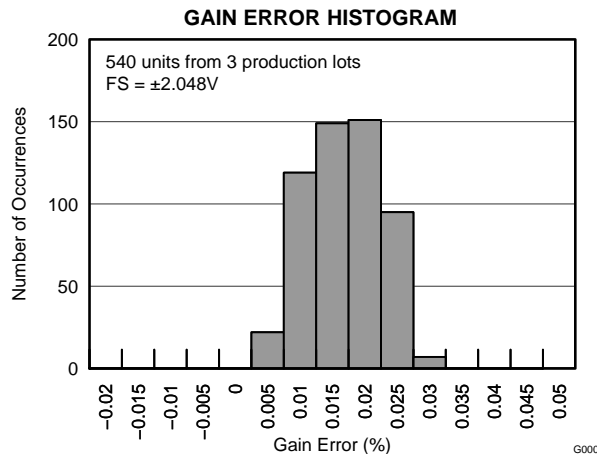

Figure 22.

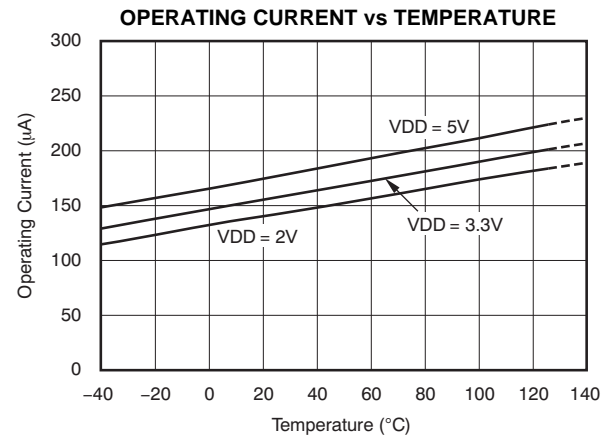

Figure 23.

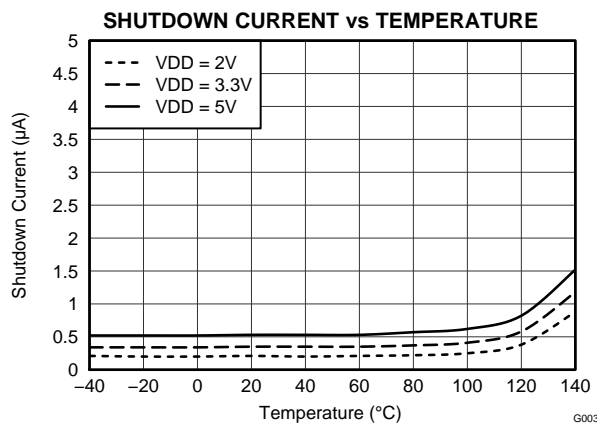

Figure 24.

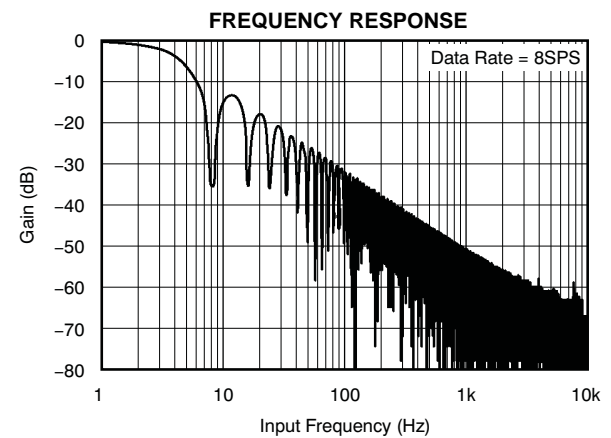
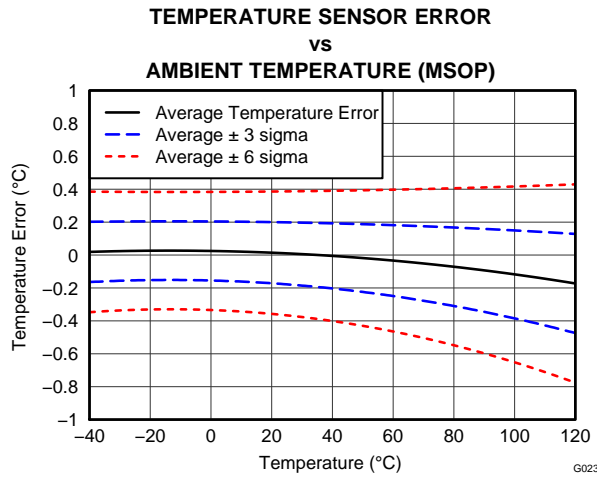

Figure 25.

**TYPICAL CHARACTERISTICS (continued)**

At  $T_A = +25^\circ\text{C}$  and  $V_{DD} = 3.3\text{V}$ , unless otherwise noted.



**Figure 26.**

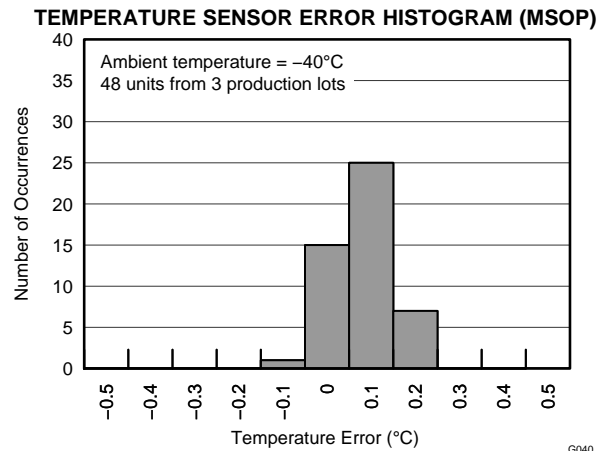

**Figure 27.**

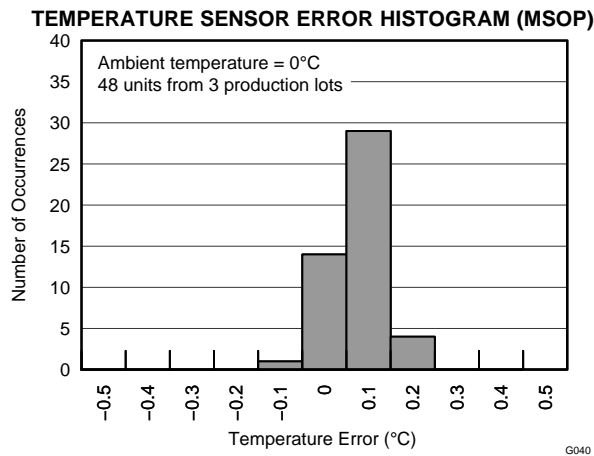

**Figure 28.**

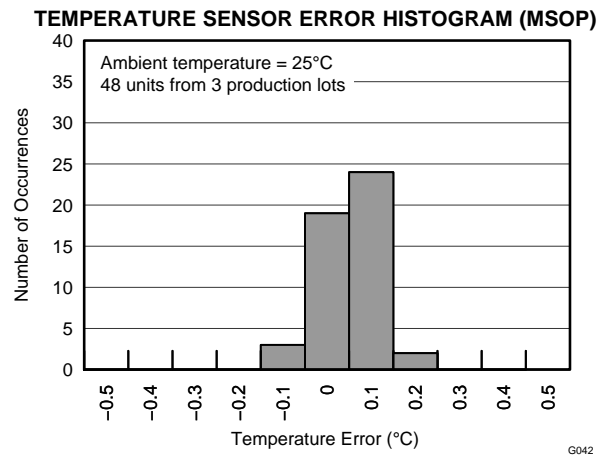

**Figure 29.**

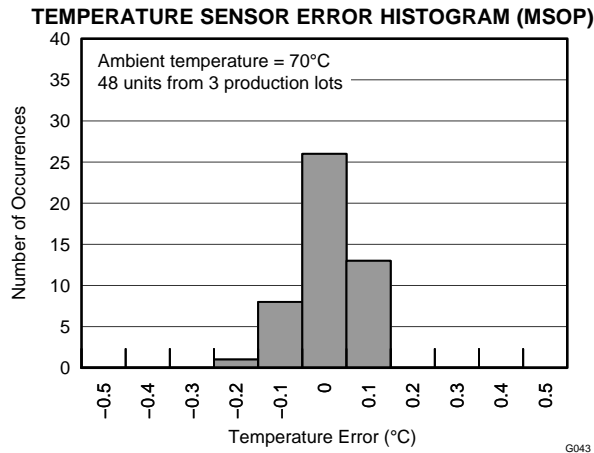

**Figure 30.**

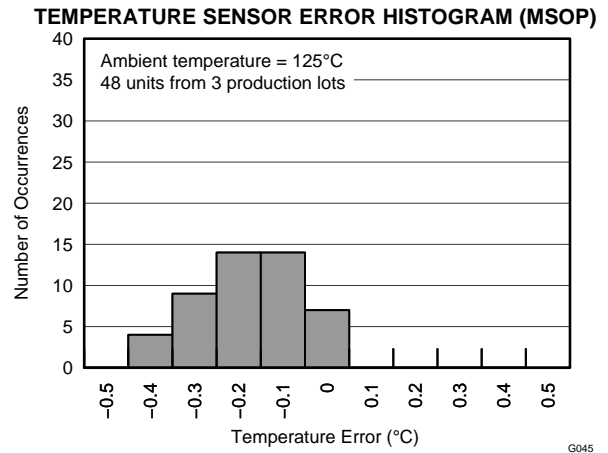

**Figure 31.**

**TYPICAL CHARACTERISTICS (continued)**

At  $T_A = +25^\circ\text{C}$  and  $V_{DD} = 3.3\text{V}$ , unless otherwise noted.

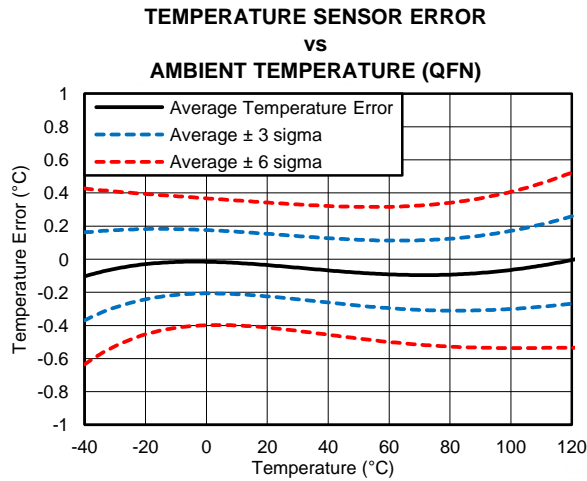

**Figure 32.**

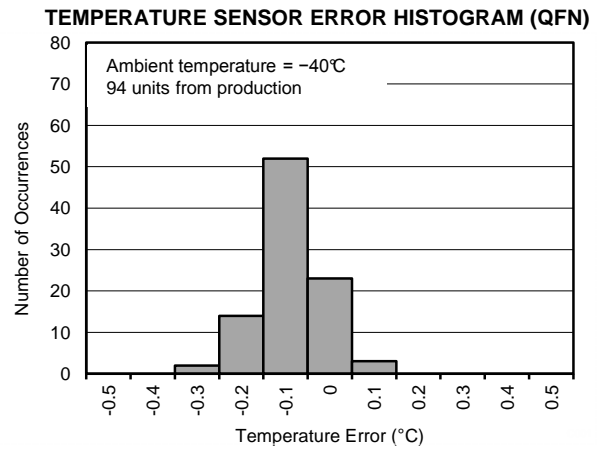

**Figure 33.**

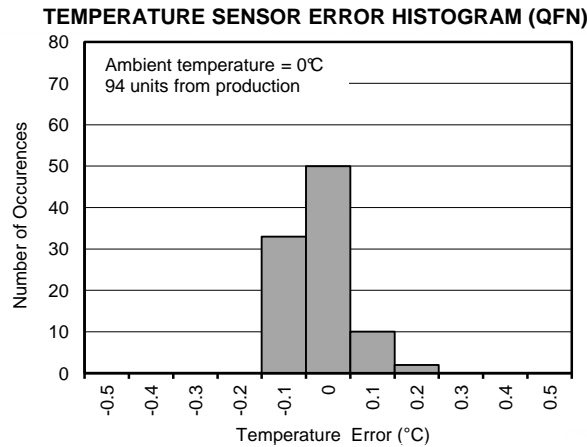

**Figure 34.**

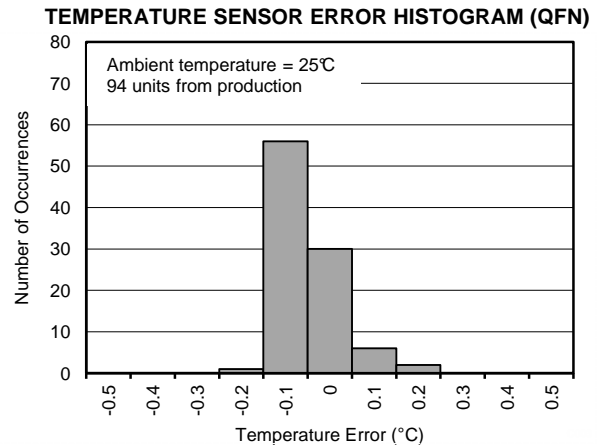

**Figure 35.**

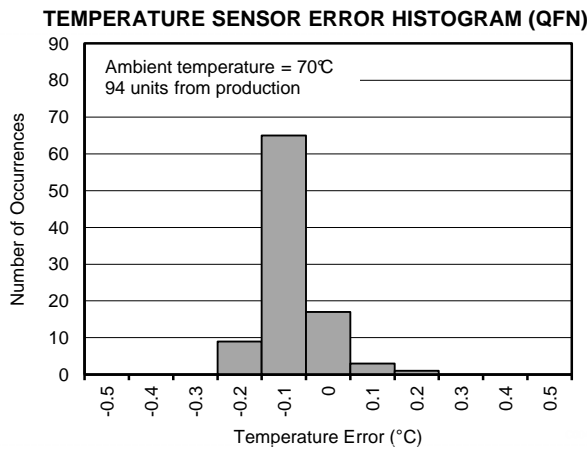

**Figure 36.**

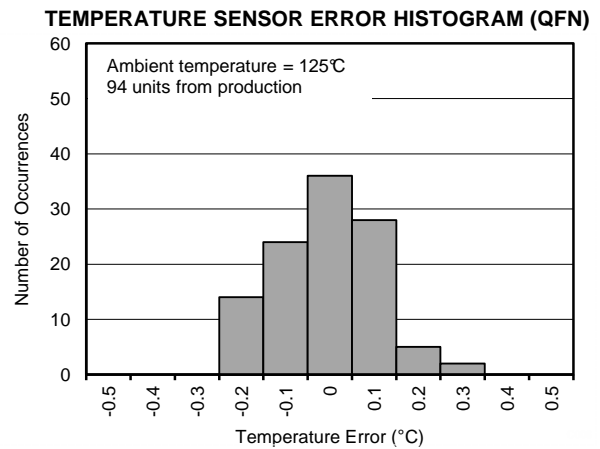
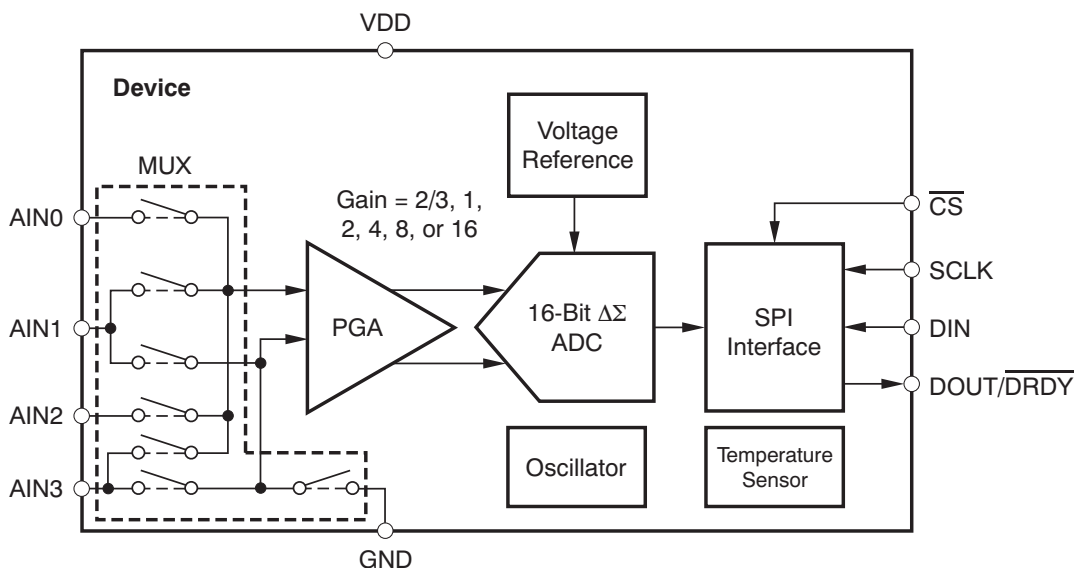

**Figure 37.**

## OVERVIEW

The ADS1118 is a very small, low-power, 16-bit, delta-sigma ( $\Delta\Sigma$ ) analog-to-digital converter (ADC). The ADS1118 is extremely easy to configure and design into a wide variety of applications, and allows precise measurements to be obtained with very little effort. Both experienced and novice users of data converters find designing with the ADS1118 family to be intuitive and problem-free.

The ADS1118 consists of a  $\Delta\Sigma$  analog-to-digital (A/D) core with adjustable gain, an internal voltage reference, a clock oscillator, and an SPI. This device is also a highly linear and accurate temperature sensor. All of these features are intended to reduce required external circuitry and improve performance. Figure 38 shows the ADS1118 functional block diagram.



**Figure 38. ADS1118 Functional Block Diagram**

The ADS1118 A/D core measures a differential signal,  $V_{IN}$ , that is the difference of  $AIN_P$  and  $AIN_N$ . The converter core consists of a differential, switched-capacitor  $\Delta\Sigma$  modulator followed by a digital filter. This architecture results in a very strong attenuation in any common-mode signals. Input signals are compared to the internal voltage reference. The digital filter receives a high-speed bitstream from the modulator and outputs a code proportional to the input voltage.

The ADS1118 has two available conversion modes: single-shot mode and continuous conversion mode. In single-shot mode, the ADC performs one conversion of the input signal upon request and stores the value to an internal conversion register. The device then enters a low-power shutdown mode. This mode is intended to provide significant power savings in systems that require only periodic conversions or when there are long idle periods between conversions. In continuous conversion mode, the ADC automatically begins a conversion of the input signal as soon as the previous conversion is completed. The rate of continuous conversion is equal to the programmed data rate. Data can be read at any time and always reflect the most recent completed conversion.

## MULTIPLEXER

The ADS1118 contains an input multiplexer, as shown in [Figure 39](#). Either four single-ended or two differential signals can be measured. Additionally, AIN0 and AIN1 may be measured differentially to AIN3. The multiplexer is configured by three bits in the Config Register. When single-ended signals are measured, the negative input of the ADC is internally connected to GND by a switch within the multiplexer.

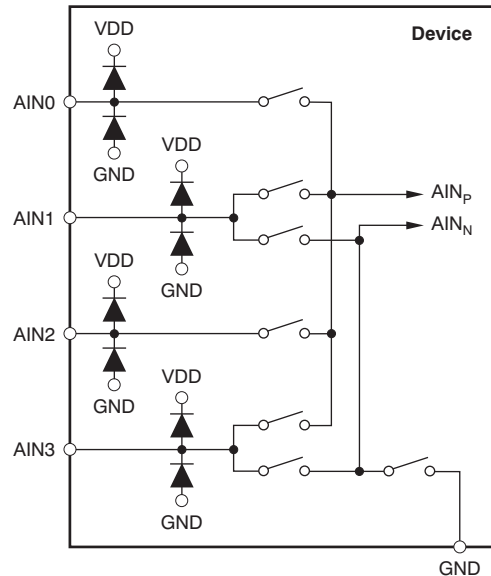

**Figure 39. ADS1118 MUX**

When measuring single-ended inputs, it is important to note that the negative range of the output codes are not used. These codes are for measuring negative differential signals, such as  $(AIN_p - AIN_n) < 0$ . Electrostatic discharge (ESD) diodes to VDD and GND protect the inputs. To prevent the ESD diodes from turning on, the absolute voltage on any input must stay within the range of [Equation 1](#):

$$GND - 0.3V < AIN_x < VDD + 0.3V \quad (1)$$

If it is possible that the voltages on the input pins may violate these conditions, external Schottky clamp diodes and/or series resistors may be required to limit the input current to safe values (see the [Absolute Maximum Ratings](#) table). While the analog inputs can support signals marginally above supply, under no circumstances should any analog or digital input or output be driven to greater than 5.5V with respect to the GND pin.

Also, overdriving one unused input on the ADS1118 may affect conversions taking place on other input pins. If overdrive on unused inputs is possible, it is recommended to clamp the signal with external Schottky diodes.

## ANALOG INPUTS

The ADS1118 uses a switched-capacitor input stage where capacitors are continuously charged and then discharged to measure the voltage between  $AIN_P$  and  $AIN_N$ . The capacitors used are small, and to external circuitry, the average loading appears resistive. This structure is shown in Figure 40. The resistance is set by the capacitor values and the rate at which they are switched. Figure 41 shows the on/off setting of the switches illustrated in Figure 40. During the sampling phase, switches  $S_1$  are closed. This event charges  $C_{A1}$  to  $AIN_P$ ,  $C_{A2}$  to  $AIN_N$ , and  $C_B$  to  $(AIN_P - AIN_N)$ . During the discharge phase,  $S_1$  is first opened and then  $S_2$  is closed. Both  $C_{A1}$  and  $C_{A2}$  then discharge to approximately 0.7V and  $C_B$  discharges to 0V. This charging draws a very small transient current from the source driving the ADS1118 analog inputs. The average value of this current can be used to calculate the effective impedance ( $R_{eff}$ ), where  $R_{eff} = V_{IN}/I_{AVERAGE}$ .

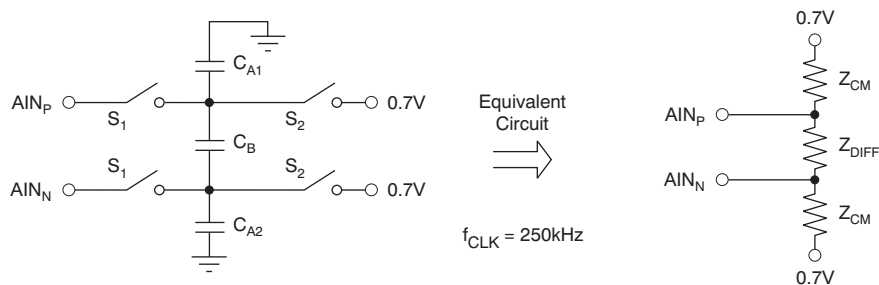

Figure 40. Simplified Analog Input Circuit

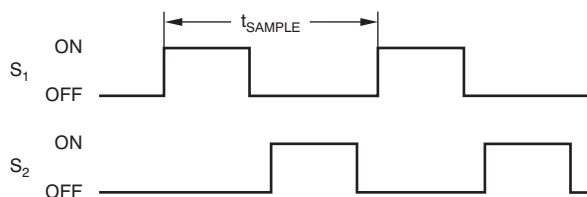

Figure 41.  $S_1$  and  $S_2$  Switch Timing for Figure 40

The common-mode input impedance is measured by applying a common-mode signal to the shorted  $AIN_P$  and  $AIN_N$  inputs and measuring the average current consumed by each pin. The common-mode input impedance changes depending on the PGA gain setting, but is approximately  $6M\Omega$  for the default PGA gain setting. In Figure 40, the common-mode input impedance is  $Z_{CM}$ .

The differential input impedance is measured by applying a differential signal to  $AIN_P$  and  $AIN_N$  inputs where one input is held at 0.7V. The current that flows through the pin connected to 0.7V is the differential current and scales with the PGA gain setting. In Figure 40, the differential input impedance is  $Z_{DIFF}$ . Table 1 describes the typical differential input impedance.

Table 1. Differential Input Impedance

FS (V)	DIFFERENTIAL INPUT IMPEDANCE
$\pm 6.144V^{(1)(1)}$	$22M\Omega$
$\pm 4.096V^{(1)(1)}$	$15M\Omega$
$\pm 2.048V$	$4.9M\Omega$
$\pm 1.024V$	$2.4M\Omega$
$\pm 0.512V$	$710k\Omega$
$\pm 0.256V$	$710k\Omega$

(1) This parameter expresses the full-scale range of the ADC scaling. In no event should more than  $V_{DD} + 0.3V$  be applied to this device.

The typical value of the input impedance cannot be neglected. Unless the input source has a low impedance, the ADS1118 input impedance may affect the measurement accuracy. For sources with high output impedance, buffering may be necessary. Note that active buffers introduce noise, and also introduce offset and gain errors. All of these factors should be considered in high-accuracy applications.

Because the clock oscillator frequency drifts slightly with temperature, the input impedances also drift. For many applications, this input impedance drift can be ignored, and the values given in [Table 1](#) for typical input impedance are valid.

## FULL-SCALE INPUT

A PGA is implemented before the  $\Delta\Sigma$  core of the ADS1118. The PGA can be set to gains of 2/3, 1, 2, 4, 8, and 16. [Table 2](#) shows the corresponding full-scale (FS) ranges. The PGA is configured by three bits in the Config register. The PGA = 2/3 setting allows input measurement to extend up to the supply voltage when VDD is larger than 4V. Note, however, in this case (as well as for PGA = 1 and VDD < 4V) that it is not possible to reach a full-scale output code on the ADC. Analog input voltages may never exceed the analog input voltage limits given in the [Electrical Characteristics](#) table.

**Table 2. PGA Gain Full-Scale Range**

PGA SETTING	FS (V)
2/3	$\pm 6.144V^{(1)(1)}$
1	$\pm 4.096V^{(1)}$
2	$\pm 2.048V$
4	$\pm 1.024V$
8	$\pm 0.512V$
16	$\pm 0.256V$

- (1) This parameter expresses the full-scale range of the ADC scaling. In no event should more than VDD + 0.3V be applied to this device.



## DATA FORMAT

The ADS1118 provides 16 bits of data in binary two's complement format. The positive full-scale input produces an output code of 7FFFh and the negative full-scale input produces an output code of 8000h. The output clips at these codes for signals that exceed full-scale. [Table 3](#) summarizes the ideal output codes for different input signals. [Figure 42](#) shows code transitions versus input voltage.

**Table 3. Input Signal versus Ideal Output Code**

INPUT SIGNAL, $V_{IN}$ ( $A_{INP} - A_{INN}$ )	IDEAL OUTPUT CODE <sup>(1)</sup>
$\geq FS (2^{15} - 1)/2^{15}$	7FFFh
$+FS/2^{15}$	0001h
0	0
$-FS/2^{15}$	FFFFh
$\leq -FS$	8000h

(1) Excludes the effects of noise, INL, offset, and gain errors.

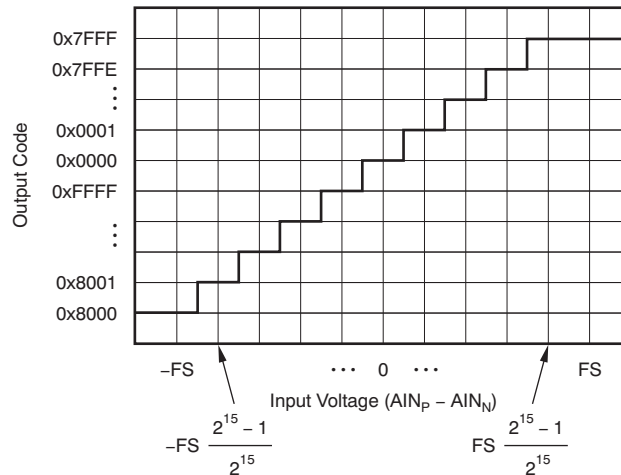

**Figure 42. ADS1118 Code Transition Diagram**

## TEMPERATURE SENSOR

The temperature measurement mode of the ADS1118 is configured as a 14-bit result when enabled. Two bytes must be read to obtain data. The first byte is the most significant byte (MSB), followed by a second byte, the least significant byte (LSB). The first 14 bits are used to indicate temperature. That is, the 14-bit temperature result is left-justified within the 16-bit result register and the last two bits always read back as '0'. One 14-bit LSB equals 0.03125°C. Negative numbers are represented in binary twos complement format.

**Table 4. 14-bit Temperature Data Format**

TEMPERATURE (°C)	DIGITAL OUTPUT (BINARY)	HEX
128	01 0000 0000 0000	1000
127.96875	00 1111 1111 1111	0FFF
100	00 1100 1000 0000	0C80
80	00 1010 0000 0000	0A00
75	00 1001 0110 0000	0960
50	00 0110 0100 0000	0640
25	00 0011 0010 0000	0320
0.25	00 0000 0000 1000	0008
0	00 0000 0000 0000	0000
-0.25	11 1111 1111 1000	3FF8
-25	11 1100 1110 0000	3CE0
-55	11 1001 0010 0000	3920

### Converting from Temperature to Digital Codes

#### For positive temperatures (for example, +50°C):

Twos complement is not performed on positive numbers. Therefore, simply convert the number to binary code in a 14-bit left justified format with the MSB = 0 to denote the positive sign.

**Example:**  $(+50^{\circ}\text{C}) / (0.03125^{\circ}\text{C}/\text{count}) = 1600 = 0640\text{h} = 00\ 0110\ 0100\ 0000$

#### For negative temperatures (for example -25°C):

Generate the twos complement of a negative number by complementing the absolute binary number and adding 1. Then denote the negative sign with the MSB = 1.

**Example:**  $(|-25^{\circ}\text{C}|) / (0.03125^{\circ}\text{C}/\text{count}) = 800 = 0320\text{h} = 00\ 0011\ 0010\ 0000$

Twos complement format:  $11\ 1100\ 1101\ 1111 + 1 = 11\ 1100\ 1110\ 0000$

### Converting from Digital Codes to Temperature

To convert from digital codes to temperature, first check whether the MSB is a '0' or a '1'. If the MSB is a '0', simply multiply the decimal code by 0.03125°C to obtain the result. If the MSB = 1, subtract '1' from the result and complement all of the bits. Then multiply the result by -0.03125°C.

**Example:** ADS1118 reads back 0960h: 0960h has an MSB = 0.

$(0960\text{h})(0.03125^{\circ}\text{C}) = (2400)(0.03125^{\circ}\text{C}) = +75^{\circ}\text{C}$

**Example:** ADS1118 reads back 3CE0h: 3CE0h has an MSB = 1.

Complement the result:  $3CE0\text{h} \rightarrow 0320\text{h}$

$(0320\text{h})(-0.03125^{\circ}\text{C}) = (800)(-0.03125^{\circ}\text{C}) = -25^{\circ}\text{C}$

## ALIASING

As with any data converter, if the input signal contains frequencies greater than half the data rate, aliasing occurs. To prevent aliasing, the input signal must be bandlimited. Some signals are inherently bandlimited; for example, the output of a thermocouple has a limited rate of change. Nevertheless, these signals can contain noise and interference components. These components can fold back into the sampling band in the same way as with any other signal.

The ADS1118 digital filter provides some attenuation of high-frequency noise, but the digital sinc filter frequency response cannot completely replace an anti-aliasing filter. For some applications, some external filtering may be needed; in such instances, a simple RC filter is adequate.

When designing an input filter circuit, be sure to take into account the interaction between the filter network and the input impedance of the ADS1118.

## OPERATING MODES

The ADS1118 operates in one of two modes: continuous conversion or single-shot. In continuous conversion mode, the ADS1118 continuously performs conversions. Once a conversion has been completed, the ADS1118 places the result in the Conversion Register and immediately begins another conversion. In single-shot mode, the ADS1118 waits until the OS bit is set high. Once asserted, the bit is set to '0', indicating that a conversion is currently in progress. Once conversion data are ready, the OS bit reasserts and the device powers down. Writing a '1' to the OS bit during a conversion has no effect.

## RESET AND POWER-UP

When the ADS1118 powers up, a reset is performed. As part of the reset process, the ADS1118 sets all of the bits in the Config Register to the respective default settings. By default, the ADS1118 enters into a power-down state at start-up. The device interface and digital are active, but no conversion occurs until the Config Register is written to. The initial power-down state of the ADS1118 is intended to relieve systems with tight power-supply requirements from encountering a surge during power-up.

## DUTY CYCLING FOR LOW POWER

For many applications, improved performance at low data rates may not be required. For these applications, the ADS1118 supports duty cycling that can yield significant power savings by periodically requesting high data rate readings at an effectively lower data rate. For example, an ADS1118 in power-down mode with a data rate set to 860SPS could be operated by a microcontroller that instructs a single-shot conversion every 125ms (8SPS). Because a conversion at 860SPS only requires about 1.2ms, the ADS1118 enters power-down mode for the remaining 123.8ms. In this configuration, the ADS1118 consumes about 1/100th the power of the ADS1118 operated in continuous conversion mode. The rate of duty cycling is completely arbitrary and is defined by the master controller.

## SERIAL INTERFACE

The SPI-compatible serial interface consists of either four signals:  $\overline{CS}$ , SCLK, DIN, and DOUT/ $\overline{DRDY}$ ; or three signals, in which case  $\overline{CS}$  may be tied low. The interface is used to read conversion data, read and write registers, and control the ADS1118 operation.

## CHIP SELECT ( $\overline{CS}$ )

The chip select ( $\overline{CS}$ ) selects the ADS1118 for SPI communication. This feature is useful when multiple devices share the serial bus.  $\overline{CS}$  must remain low for the duration of the serial communication. When  $\overline{CS}$  is taken high, the serial interface is reset, SCLK is ignored, and DOUT/ $\overline{DRDY}$  enters a high-impedance state; as such, DOUT/ $\overline{DRDY}$  cannot provide indication of data ready. In situations where multiple devices are present and DOUT/ $\overline{DRDY}$  must be monitored; by periodically lowering  $\overline{CS}$ , the DOUT/ $\overline{DRDY}$  pin either immediately goes high to indicate that no new data are available, or it immediately goes low, to indicate that new data are present in the Config Register and are available for transfer. New data can be transferred at anytime without concern of data corruption. When a transmission starts, the current result is locked into the output shift register and does not change until the communication is completed. This system avoids any possibility of data corruption.

## SERIAL CLOCK (SCLK)

The serial clock (SCLK) features a Schmitt-triggered input and is used to clock data on the DIN and DOUT/DRDY pins into and out of the ADS1118. Even though the input has hysteresis, it is recommended to keep SCLK as clean as possible to prevent glitches from accidentally shifting the data. If SCLK is held low for 28ms, the serial interface resets and the next SCLK pulse starts a new communication cycle. This timeout feature can be used to recover communication when a serial interface transmission is interrupted. When the serial interface is idle, hold SCLK low.

## DATA INPUT (DIN)

The data input pin (DIN) is used along with SCLK to send data to the ADS1118 (op code commands and register data). The device latches data on DIN on the falling edge of SCLK. The ADS1118 never drives the DIN pin.

## DATA OUTPUT AND DATA READY (DOUT/ $\overline{\text{DRDY}}$ )

The data output and data ready pin (DOUT/ $\overline{\text{DRDY}}$ ) are used with SCLK to read conversion and register data from the ADS1118. In Read Data Continuous mode, DOUT/ $\overline{\text{DRDY}}$  goes low when conversion data are ready and goes high 8 $\mu$ s before the data ready signal. Data on DOUT/ $\overline{\text{DRDY}}$  are shifted out on the rising edge of SCLK. By default DOUT/ $\overline{\text{DRDY}}$  goes to a high-impedance state when  $\overline{\text{CS}}$  is high. Alternatively, the ADS1118 DOUT/ $\overline{\text{DRDY}}$  pin can be configured as a weak pull-up if  $\overline{\text{CS}}$  is high. This feature is intended to reduce the risk of DOUT/ $\overline{\text{DRDY}}$  floating near midsupply and causing leakage current in the master. If the ADS1118 does not share the serial bus with another device,  $\overline{\text{CS}}$  may be tied low.

## POWER-DOWN MODE

When the PWDN bit in the Config Register is set to '1', the ADS1118 enters a lower power standby state. This condition is also the default state the ADS1118 enters when power is first supplied. In this mode, the ADS1118 uses no more than 2 $\mu$ A of current. During this time, the device responds to commands, but does not perform any data conversion. To exit this mode, simply write a '0' to the PWDN bit in the Config Register.

## REGISTERS

The ADS1118 has two registers that are accessible via the SPI port. The Conversion Register contains the result of the last conversion. The Config Register allows the modification of the ADS1118 operating modes and the ability to query the status of the device.

### Conversion Register

This 16-bit register contains the result of the last conversion in binary twos complement format. Following power-up, the Conversion Register is cleared to '0', and remains '0' until the first conversion is completed.

The register format is shown in [Table 5](#).

**Table 5. Conversion Register (Read-Only)**

BIT	15	14	13	12	11	10	9	8	7	6	5	4	3	2	1	0
NAME	D15	D14	D13	D12	D11	D10	D9	D8	D7	D6	D5	D4	D3	D2	D1	D0

### Config Register

The 16-bit register can be used to control the ADS1118 operating mode, input selection, data rate, PGA settings, and comparator modes. The register format is shown in [Table 6](#).

**Table 6. Config Register (Read/Write)**

BIT	15	14	13	12	11	10	9	8
NAME	OS	MUX2	MUX1	MUX0	PGA2	PGA1	PGA0	MODE

BIT	7	6	5	4	3	2	1	0
NAME	DR2	DR1	DR0	TS_MODE	PULL_UP_EN	NOP1	NOP2	CNV_RDY_FL

Default = 8583h.

**Bit 15 OS: Operational status/single-shot conversion start**

This bit determines the operational status of the device. This bit can only be written when in power-down mode.

For a write status:

0 : No effect

1 : Begin a single conversion (when in power-down mode)

For a read status:

0 : Device is currently performing a conversion

1 : Device is not currently performing a conversion

**Bits[14:12] MUX[2:0]: Input multiplexer configuration**

These bits configure the input multiplexer. No effect when in temperature sensor mode.

000 : AIN<sub>P</sub> = AIN0 and AIN<sub>N</sub> = AIN1 (default)

100 : AIN<sub>P</sub> = AIN0 and AIN<sub>N</sub> = GND

001 : AIN<sub>P</sub> = AIN0 and AIN<sub>N</sub> = AIN3

101 : AIN<sub>P</sub> = AIN1 and AIN<sub>N</sub> = GND

010 : AIN<sub>P</sub> = AIN1 and AIN<sub>N</sub> = AIN3

110 : AIN<sub>P</sub> = AIN2 and AIN<sub>N</sub> = GND

011 : AIN<sub>P</sub> = AIN2 and AIN<sub>N</sub> = AIN3

111 : AIN<sub>P</sub> = AIN3 and AIN<sub>N</sub> = GND

**Bits[11:9] PGA[2:0]: Programmable gain amplifier configuration**

These bits configure the programmable gain amplifier. No effect when in temperature sensor mode.

000 : FS = ±6.144V<sup>(1)</sup>

100 : FS = ±0.512V

001 : FS = ±4.096V<sup>(1)</sup>

101 : FS = ±0.256V

010 : FS = ±2.048V (default)

110 : FS = ±0.256V

011 : FS = ±1.024V

111 : FS = ±0.256V

**Bit 8 MODE: Device operating mode**

This bit controls the current operational mode of the ADS1118.

0 : Continuous conversion mode

1 : Power-down single-shot mode (default)

(1) This parameter expresses the full-scale range of the ADC scaling. In no event should more than VDD + 0.3V be applied to this device.

<b>Bits[7:5]</b>	<p><b>DR[2:0]: Data rate</b></p> <p>These bits control the data rate setting.</p> <table border="0"> <tr> <td>000 : 8SPS</td> <td>100 : 128SPS (default)</td> </tr> <tr> <td>001 : 16SPS</td> <td>101 : 250SPS</td> </tr> <tr> <td>010 : 32SPS</td> <td>110 : 475SPS</td> </tr> <tr> <td>011 : 64SPS</td> <td>111 : 860SPS</td> </tr> </table>	000 : 8SPS	100 : 128SPS (default)	001 : 16SPS	101 : 250SPS	010 : 32SPS	110 : 475SPS	011 : 64SPS	111 : 860SPS
000 : 8SPS	100 : 128SPS (default)								
001 : 16SPS	101 : 250SPS								
010 : 32SPS	110 : 475SPS								
011 : 64SPS	111 : 860SPS								
<b>Bit 4</b>	<p><b>TS_MODE: Temperature sensor mode</b></p> <p>This bit configures the ADC to convert temperature or input signals.</p> <p>0 : ADC mode (default) 1 : Temperature sensor mode</p>								
<b>Bit 3</b>	<p><b>PULL_UP_EN: Pull-up enable</b></p> <p>This bit enables a weak pull-up resistor on the DOUT pin when <math>\overline{CS}</math> is high. When enabled, a 400k<math>\Omega</math> resistor connects the bus line to supply when <math>\overline{CS}</math> is high. When disabled, the DOUT pin floats when <math>\overline{CS}</math> is high.</p> <p>0 : Pull-up resistor disabled on DOUT pin (default) 1 : Pull-up resistor enabled on DOUT pin</p>								
<b>Bits[2:0]</b>	<p><b>NOP: No operation</b></p> <p>The NOP bits control whether data are written to the Config Register or not. In order for data to be written to the Config Register, the NOP bits must be written as '01'. Any other value written to the NOP bits results in a NOP command. This means that DIN can be held high or low during SCLK pulses without data being written to the Config Register.</p> <p>00 : Invalid data, do not update the contents of the Config Register. 01 : Valid data, update the Config Register (default) 10 : Invalid data, do not update the contents of the Config Register. 11 : Invalid data, do not update the contents of the Config Register.</p>								
<b>Bit 0</b>	<p><b>CNV_RDY_FL: Conversion ready flag</b></p> <p>This bit is active low and indicates when data are ready from the converter. When it is high, a conversion is not yet ready and is in process. The purpose of the conversion ready flag bit is to return the DOUT pin line to a high state to prepare for the falling edge from new data.</p> <p>0 : Data ready, no conversion in progress 1 : Data not ready, conversion in progress (default)</p>								

## DATA RETRIEVAL

Data may be read in one of two modes: Single-Shot and Continuous Conversion mode. The mode is selected by writing to the OS bit in the Config Register.

### Continuous Conversion Mode

In Continuous Conversion mode, the conversion data are read from the device without an op code command. When  $\overline{\text{DOUT}}/\overline{\text{DRDY}}$  asserts low (indicating that new conversion data are ready), the conversion data are read by shifting the data out on DOUT. The MSB of the data (bit 15) on  $\overline{\text{DOUT}}/\overline{\text{DRDY}}$  is clocked out on the first rising edge of SCLK.

As shown in Figure 43, the data consist of two bytes for the conversion result and an additional two bytes for the Config Register readback. The data read operation must be completed  $16/f_{\text{CLK}}$  cycles before  $\overline{\text{DOUT}}$  asserts again.

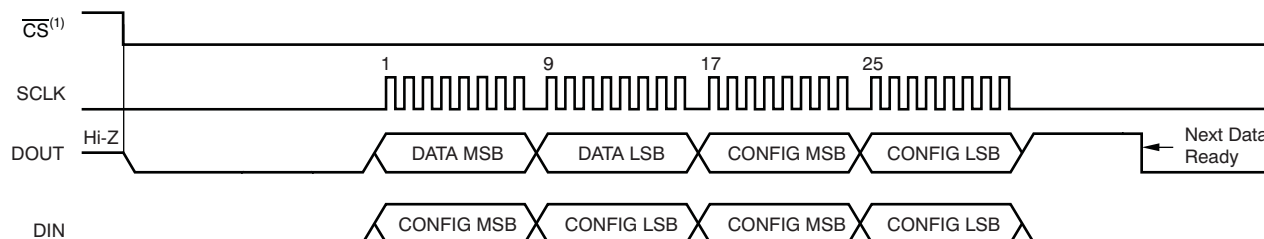

(1)  $\overline{\text{CS}}$  may be held low. If  $\overline{\text{CS}}$  is low,  $\overline{\text{DOUT}}/\overline{\text{DRDY}}$  asserts low indicating new data.

**Figure 43. Continuous Conversion Mode Timing**

### One-Shot Mode

In One-Shot mode, the conversion data are buffered, holding the current data until new conversion data replace it. The conversion data are read by writing a '1' to the OS bit, followed by shifting the conversion data out.

The data consist of two bytes for the conversion result and two bytes for the Config Register; see Figure 44. In contrast to the Continuous Conversion mode,  $\overline{\text{DOUT}}$  does not assert low in one-shot mode.

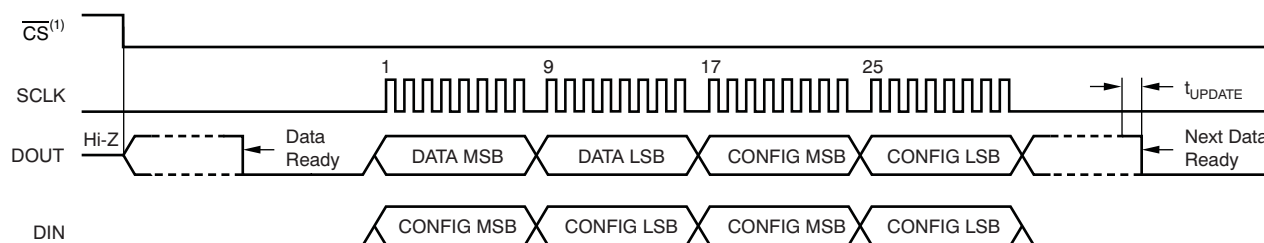

(1)  $\overline{\text{CS}}$  may be held low. If  $\overline{\text{CS}}$  is low,  $\overline{\text{DOUT}}/\overline{\text{DRDY}}$  asserts low indicating new data.

**Figure 44. One-Shot Mode Timing**

## APPLICATION INFORMATION

The following sections give example circuits and suggestions for using the ADS1118 in various situations.

### BASIC CONNECTIONS AND LAYOUT CONSIDERATIONS

For many applications, connecting the ADS1118 is simple. A basic connection diagram for the ADS1118 is shown in [Figure 45](#). Most microcontroller SPI peripherals can operate with the ADS1118. The interface operates in SPI mode 1 where CPOL = 0 and CPHA = 1. In SPI mode 1, SCLK idles low and data launch or are changed only on rising edges of SCLK and data are latched or read by the master and slave on falling edges of SCLK. Details of the SPI communication protocol employed by the ADS1118 can be found in the [SPI Timing Characteristics](#) section. Although it is not required, it is a good practice to place 49.9Ω resistors in series with all of the digital pins. This resistance smooths sharp transitions, suppresses overshoot, and offers some overvoltage protection.

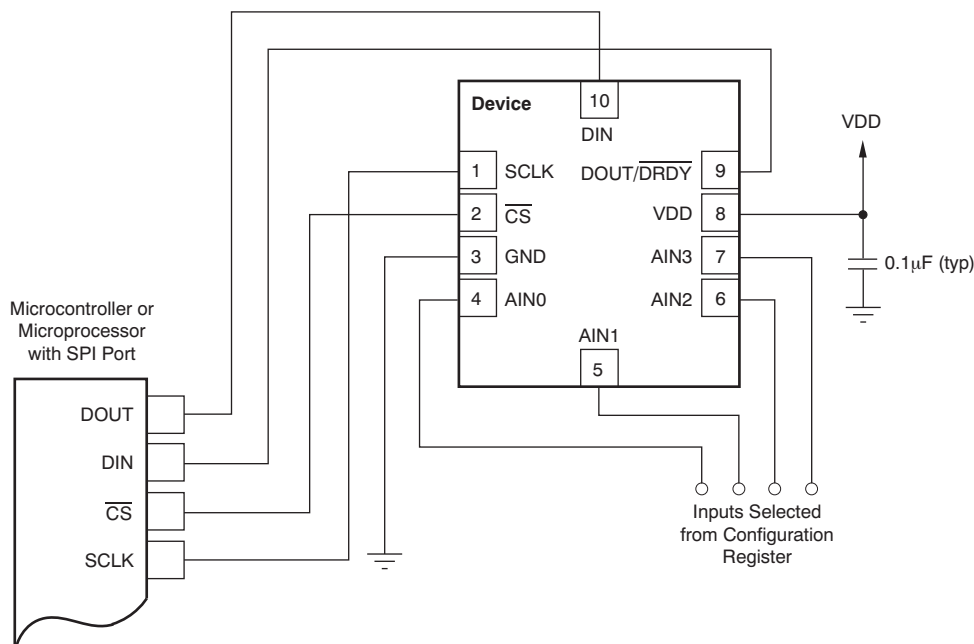

**Figure 45. Typical Connections of the ADS1118**

The fully differential voltage input of the ADS1118 is ideal for connection to differential sources with moderately low source impedance, such as thermocouples and thermistors. Although the ADS1118 can read bipolar differential signals, it cannot accept negative voltages on either input because every pin on the ADS1118 employs the use of ESD protection diodes. In the event that an input exceeds supply or drops below ground, these diodes begin to turn on. Therefore, it may be helpful to think of the ADS1118 positive voltage input as *noninverting*, and of the negative input as *inverting*.

When the ADS1118 is converting data, it draws current in short spikes. The 0.1µF bypass capacitor supplies the momentary bursts of extra current needed from the supply. This bypass capacitor should be placed as close to the device as possible. For very sensitive systems, or systems in harsh noise environments, avoiding the use of vias for connecting the bypass capacitor may offer superior bypass and noise immunity.



It is recommended to employ best design practices when laying out a printed circuit board (PCB) for both analog and digital components. This recommendation generally means that the layout should separate analog components [such as ADCs, op amps, references, digital-to-analog converters (DACs), and analog MUXs] from digital components [such as microcontrollers, complex programmable logic devices (CPLDs), field-programmable gate arrays (FPGAs), radio frequency (RF) transceivers, universal serial bus (USB) transceivers, and switching regulators]. An example of good component placement is shown in [Figure 46](#). While [Figure 46](#) provides a good example of component placement, the best placement for each application is unique to the geometries, components, and PCB fabrication capabilities being employed. That is, there is no single layout that is perfect for every design and careful consideration must always be used when designing with any analog components.

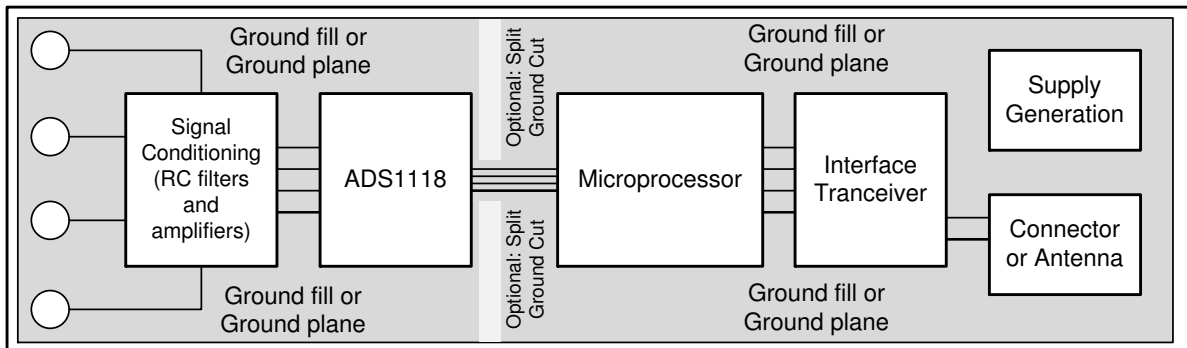
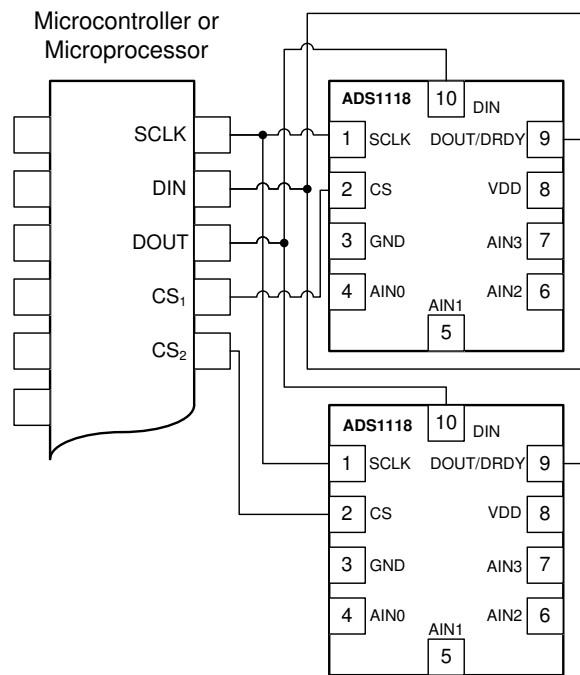

**Figure 46. System Component Placement**

The usage of split analog and digital ground planes is not necessary for improved noise performance (although for thermal isolation it is a worthwhile consideration). However, the use of a solid ground plane or ground fill in PCB areas with no components is essential for optimum performance. If the system being used employs a split digital and analog ground plane, it is generally recommended that the ground planes be connected as close to the ADS1118 as possible. It is also strongly recommended that digital components, especially RF portions, be kept as far as practically possible from analog circuitry in a given system. Additionally, minimize the distance that digital control traces run through analog areas and avoid allowing these traces to be near sensitive analog components. Digital return currents usually flow through a ground path that is as close to the digital path as possible. If a solid ground connection to a plane is not available, these currents may find paths back to the source that interfere with analog performance. The implications that layout has on the temperature sensing functions are much more significant than they are for the ADC functions. Details on layout considerations for the temperature sensor can be found in the [Thermocouple Measurement with Cold Junction Compensation](#) section. For a detailed layout example, refer to the [ADS1118EVM User's Guide \(SBAU184\)](#).

### CONNECTING MULTIPLE DEVICES

Connecting multiple ADS1118s to a single bus is simple. Using a dedicated chip-select ( $\overline{CS}$ ) for each SPI enabled device, SCLK, DIN, and DOUT/DRDY can be safely shared. By default, when  $\overline{CS}$  goes high for the ADS1118, DOUT/DRDY enters a 3-state mode. If the PULL\_UP\_EN bit is enabled, the DOUT/DRDY pin is pulled up to the supply of the ADS1118 by a weak 400k $\Omega$  resistor. This feature is intended to prevent DOUT/DRDY from floating near mid-rail and causing excess current leakage on a microcontroller input. The ADS1118 cannot issue a data ready pulse on DOUT/DRDY when  $\overline{CS}$  is high. In order to evaluate when a new conversion is ready from the ADS1118 when using multiple devices, the master can periodically drop  $\overline{CS}$  to the ADS1118. When  $\overline{CS}$  lowers, the DOUT/DRDY pin immediately drives either high or low. If the DOUT/DRDY line drives low on a low  $\overline{CS}$ , new data are currently available for clocking out at any time. If the DOUT/DRDY line drives high, no new data are available and the ADS1118 returns the last read conversion result. Valid data can be retrieved from the ADS1118 at anytime without concern of data corruption. When SCLK rises, the current result is locked into DOUT/DRDY the output shift register. If a new conversion becomes available during data transmission, it is not available for readback until a new SPI transmission is initiated.



NOTE: Power and input connections omitted for clarity.

**Figure 47. Connecting Multiple ADS1118s**

## USING GPIO PORTS FOR COMMUNICATION

Most microcontrollers have programmable input/output (I/O) pins that can be set in software to act as inputs or outputs. If an SPI controller is not available, the ADS1118 can be connected to GPIO pins and the SPI bus protocol can be simulated. Using GPIO pins to generate the SPI interface only requires that the pins be configured as push/pull inputs or outputs. Furthermore, if the SCLK line is held low for more than 28ms, the communication times out. This condition means that the GPIO ports must be capable of providing SCLK pulses with no more than 28ms between pulses.

## SINGLE-ENDED INPUTS

Although the ADS1118 has two differential inputs, the device can easily measure four single-ended signals. [Figure 48](#) shows a single-ended connection scheme. The ADS1118 is configured for single-ended measurement by configuring the MUX to measure each channel with respect to ground. Data are then read out of one input based on the selection in the Config Register. The single-ended signal can range from 0V to supply. The ADS1118 loses no linearity anywhere within the input range. Negative voltages cannot be applied to this circuit because the ADS1118 can only accept positive voltages.

The ADS1118 input range is bipolar differential. The single-ended circuit shown in [Figure 48](#) covers only half the ADS1118 input scale because it does not produce differentially negative inputs; therefore, one bit of resolution is lost. For optimal noise performance, it is recommended to use differential configurations whenever possible. Differential configurations maximize the dynamic range of the ADC and provide strong attenuation of common-mode noise.

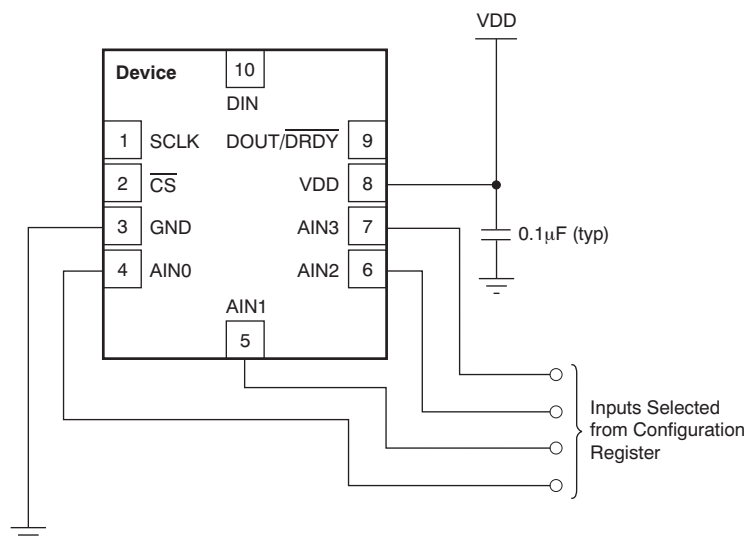

NOTE: Digital pin connections omitted for clarity.

**Figure 48. Measuring Single-Ended Inputs**

The ADS1118 is also designed to allow AIN3 to serve as a common point for measurements by adjusting the MUX configuration. AIN0, AIN1, and AIN2 can all be measured with respect to AIN3. In this configuration the ADS1118 can operate with inputs where AIN3 serves as the common point. This ability improves the usable range over the single-ended configuration because it allows negative voltages; however, it does not offer attenuation of common-mode noise.

## THERMOCOUPLE MEASUREMENT WITH COLD JUNCTION COMPENSATION

For an independent, two-channel thermocouple system, [Figure 49](#) shows the basic connections. This circuit contains a simple low-pass, anti-aliasing filter, mid-point bias, and open detection. While the digital filter of the ADS1118 strongly attenuates high-frequency components of noise, it is generally recommended to provide a first-order passive RC filter to further improve this performance. The differential RC filter formed by the 500Ω resistors ( $R_{DIFFA}$  and  $R_{DIFFB}$ ) and the 1μF ( $C_{DIFF}$ ) capacitor offers a cutoff frequency of approximately 320Hz. Additional filtering can be achieved by increasing the differential capacitor or the resistance values. However, avoid increasing the filter resistance beyond 1kΩ because the effects of the interaction with ADCs input impedance begin to affect the linearity and gain error of the ADS1118. Because of the high sampling rates supported by the ADS1118, simple post digital filtering in a microcontroller can alleviate the requirements of the analog filter and can also offer the flexibility to implement filter notches at 50Hz or 60Hz. Two 0.1μF ( $C_{CMA}$  and  $C_{CMB}$ ) capacitors are also added to offer attenuation of high-frequency common-mode noise components. Because mismatches in the common-mode capacitors cause differential noise, it is recommended that the differential capacitor be at least an order of magnitude (10x) larger than the common-mode capacitors.

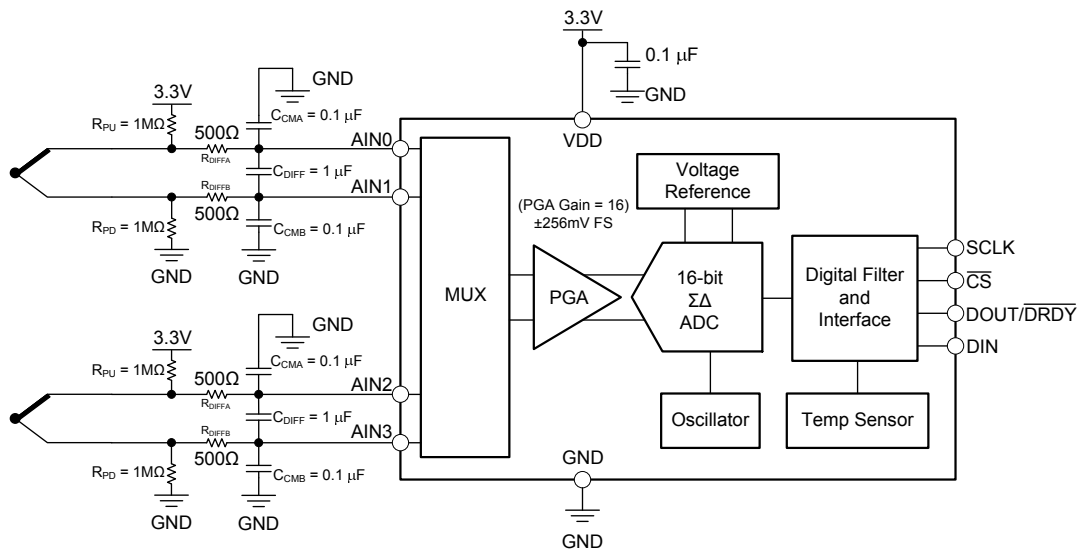

**Figure 49. Two-Channel Thermocouple System**

The two 1M $\Omega$  resistors ( $R_{PU}$  and  $R_{PD}$ ) serve two purposes. The first purpose is to offer a common-mode bias near midsupply. While the ADS1118 does offer the ability to *float* the common-mode of a signal or connect any of the inputs to a common point such as ground or supply, it is generally recommended to avoid such situations. Connecting one of the inputs to a common point decreases performance by converting common-mode noise into differential signal noise that is not strongly attenuated. The second purpose of the 1M $\Omega$  resistors is to offer a weak pull-up and pull-down for sensor open detection. In the event that a sensor is disconnected, the inputs to the ADC extend to supply and ground and yield a full-scale readout, indicating a sensor disconnection.

The procedure to actually achieve cold junction compensation is simple and can be done in several ways. One way is to interleave readings between the thermocouple inputs and the temperature sensor. That is, acquire one on-chip temperature result for every thermocouple ADC voltage measured. If the cold junction is in a very stable environment, more periodic cold junction measurements may be sufficient. These operations yield two results for every thermocouple measurement and cold junction measurement cycle: the thermocouple voltage or  $V_{TC}$  and the on-chip temperature or  $T_{CJC}$ . In order to account for the cold junction, the temperature sensor within the ADS1118 must first be converted to a voltage proportional to the thermocouple currently being used yielding  $V_{CJC}$ . This conversion is generally accomplished by performing a reverse lookup on the table being used for the thermocouple voltage to temperature conversion. Then, adding the two voltages yields the thermocouple compensated voltage  $V_{Actual}$  where  $V_{CJC} + V_{TC} = V_{Actual}$ .  $V_{Actual}$  is then converted to temperature using the same lookup table from before, yielding  $T_{Actual}$ .

Thermocouple manufacturers usually supply a lookup table with their thermocouples that offer excellent accuracy for linearization of a specific type of thermocouple. The granularity on these lookup tables is generally very precise (at around 1 $^{\circ}$ C for each lookup value). To save microcontroller memory and development time, an interpolation technique applied to these values can be used. By choosing 16 to 32 equally-spaced values from the manufacturer's lookup tables over a desired temperature range, using a simple linear approximation of intervals between is generally very precise.

### REVISION HISTORY

NOTE: Page numbers for previous revisions may differ from page numbers in the current version.

Changes from Revision A (July 2011) to Revision B	Page
• Added (MSOP) to titles of <a href="#">Figure 26</a> to <a href="#">Figure 31</a> .....	11
• Added <a href="#">Figure 32</a> to <a href="#">Figure 37</a> .....	12

**PACKAGING INFORMATION**

Orderable Device	Status <sup>(1)</sup>	Package Type	Package Drawing	Pins	Package Qty	Eco Plan <sup>(2)</sup>	Lead/ Ball Finish	MSL Peak Temp <sup>(3)</sup>	Samples (Requires Login)
ADS1118IDGSR	ACTIVE	MSOP	DGS	10	2500	Green (RoHS & no Sb/Br)	CU NIPDAU	Level-2-260C-1 YEAR	
ADS1118IDGST	ACTIVE	MSOP	DGS	10	250	Green (RoHS & no Sb/Br)	CU NIPDAU	Level-2-260C-1 YEAR	
ADS1118IRUGR	ACTIVE	X2QFN	RUG	10	3000	Green (RoHS & no Sb/Br)	CU NIPDAU	Level-1-260C-UNLIM	
ADS1118IRUGT	ACTIVE	X2QFN	RUG	10	250	Green (RoHS & no Sb/Br)	CU NIPDAU	Level-1-260C-UNLIM	

<sup>(1)</sup> The marketing status values are defined as follows:

**ACTIVE:** Product device recommended for new designs.

**LIFEBUY:** TI has announced that the device will be discontinued, and a lifetime-buy period is in effect.

**NRND:** Not recommended for new designs. Device is in production to support existing customers, but TI does not recommend using this part in a new design.

**PREVIEW:** Device has been announced but is not in production. Samples may or may not be available.

**OBSELETE:** TI has discontinued the production of the device.

<sup>(2)</sup> Eco Plan - The planned eco-friendly classification: Pb-Free (RoHS), Pb-Free (RoHS Exempt), or Green (RoHS & no Sb/Br) - please check <http://www.ti.com/productcontent> for the latest availability information and additional product content details.

**TBD:** The Pb-Free/Green conversion plan has not been defined.

**Pb-Free (RoHS):** TI's terms "Lead-Free" or "Pb-Free" mean semiconductor products that are compatible with the current RoHS requirements for all 6 substances, including the requirement that lead not exceed 0.1% by weight in homogeneous materials. Where designed to be soldered at high temperatures, TI Pb-Free products are suitable for use in specified lead-free processes.

**Pb-Free (RoHS Exempt):** This component has a RoHS exemption for either 1) lead-based flip-chip solder bumps used between the die and package, or 2) lead-based die adhesive used between the die and leadframe. The component is otherwise considered Pb-Free (RoHS compatible) as defined above.

**Green (RoHS & no Sb/Br):** TI defines "Green" to mean Pb-Free (RoHS compatible), and free of Bromine (Br) and Antimony (Sb) based flame retardants (Br or Sb do not exceed 0.1% by weight in homogeneous material)

<sup>(3)</sup> MSL, Peak Temp. -- The Moisture Sensitivity Level rating according to the JEDEC industry standard classifications, and peak solder temperature.

**Important Information and Disclaimer:** The information provided on this page represents TI's knowledge and belief as of the date that it is provided. TI bases its knowledge and belief on information provided by third parties, and makes no representation or warranty as to the accuracy of such information. Efforts are underway to better integrate information from third parties. TI has taken and continues to take reasonable steps to provide representative and accurate information but may not have conducted destructive testing or chemical analysis on incoming materials and chemicals. TI and TI suppliers consider certain information to be proprietary, and thus CAS numbers and other limited information may not be available for release.

In no event shall TI's liability arising out of such information exceed the total purchase price of the TI part(s) at issue in this document sold by TI to Customer on an annual basis.

**TAPE AND REEL INFORMATION**

**REEL DIMENSIONS**

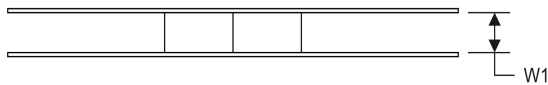
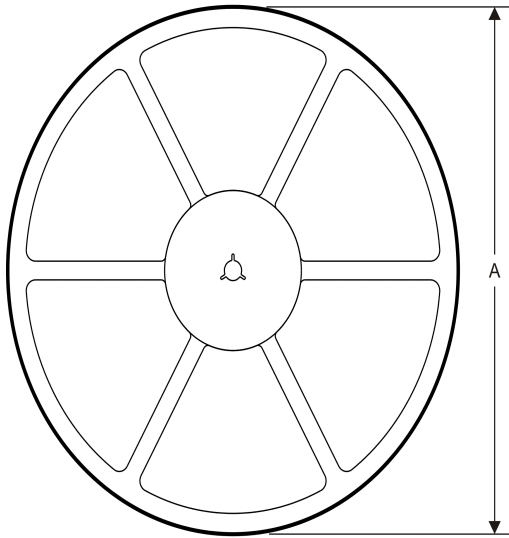

**TAPE DIMENSIONS**

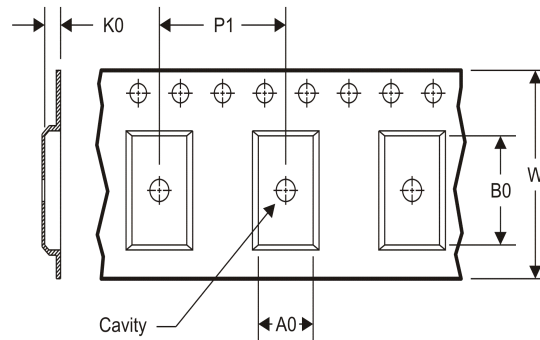

A0	Dimension designed to accommodate the component width
B0	Dimension designed to accommodate the component length
K0	Dimension designed to accommodate the component thickness
W	Overall width of the carrier tape
P1	Pitch between successive cavity centers

**TAPE AND REEL INFORMATION**

\*All dimensions are nominal

Device	Package Type	Package Drawing	Pins	SPQ	Reel Diameter (mm)	Reel Width W1 (mm)	A0 (mm)	B0 (mm)	K0 (mm)	P1 (mm)	W (mm)	Pin1 Quadrant
ADS1118IDGSR	MSOP	DGS	10	2500	330.0	12.4	5.3	3.3	1.3	8.0	12.0	Q1
ADS1118IDGST	MSOP	DGS	10	250	180.0	12.4	5.3	3.3	1.3	8.0	12.0	Q1



**TAPE AND REEL BOX DIMENSIONS**



\*All dimensions are nominal

Device	Package Type	Package Drawing	Pins	SPQ	Length (mm)	Width (mm)	Height (mm)
ADS1118IDGSR	MSOP	DGS	10	2500	370.0	355.0	55.0
ADS1118IDGST	MSOP	DGS	10	250	195.0	200.0	45.0

DGS (S-PDSO-G10)

PLASTIC SMALL-OUTLINE PACKAGE

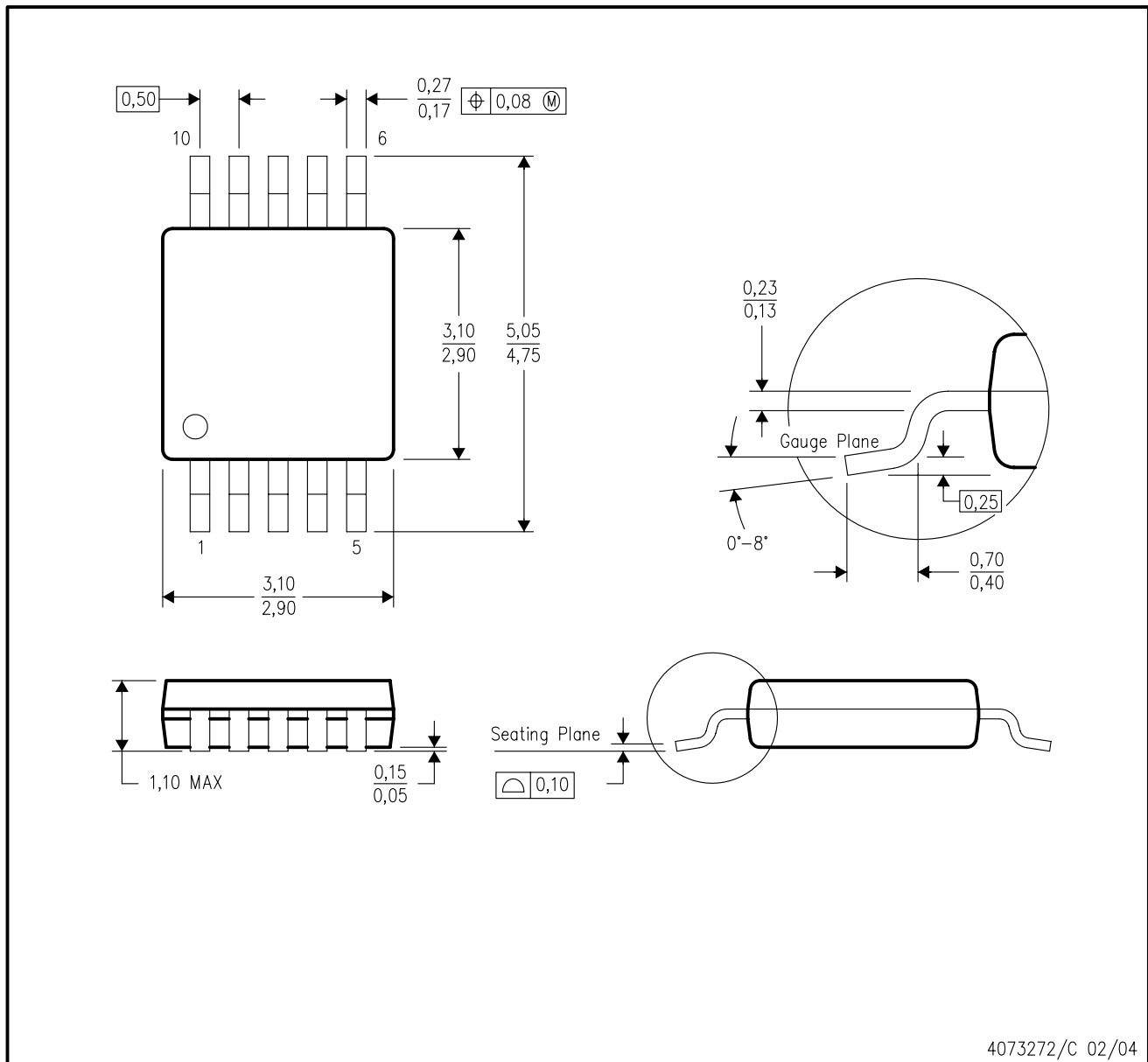

- NOTES:
- A. All linear dimensions are in millimeters.
  - B. This drawing is subject to change without notice.
  - C. Body dimensions do not include mold flash or protrusion.
  - D. Falls within JEDEC MO-187 variation BA.

RUG (R-PQFP-N10)

PLASTIC QUAD FLATPACK

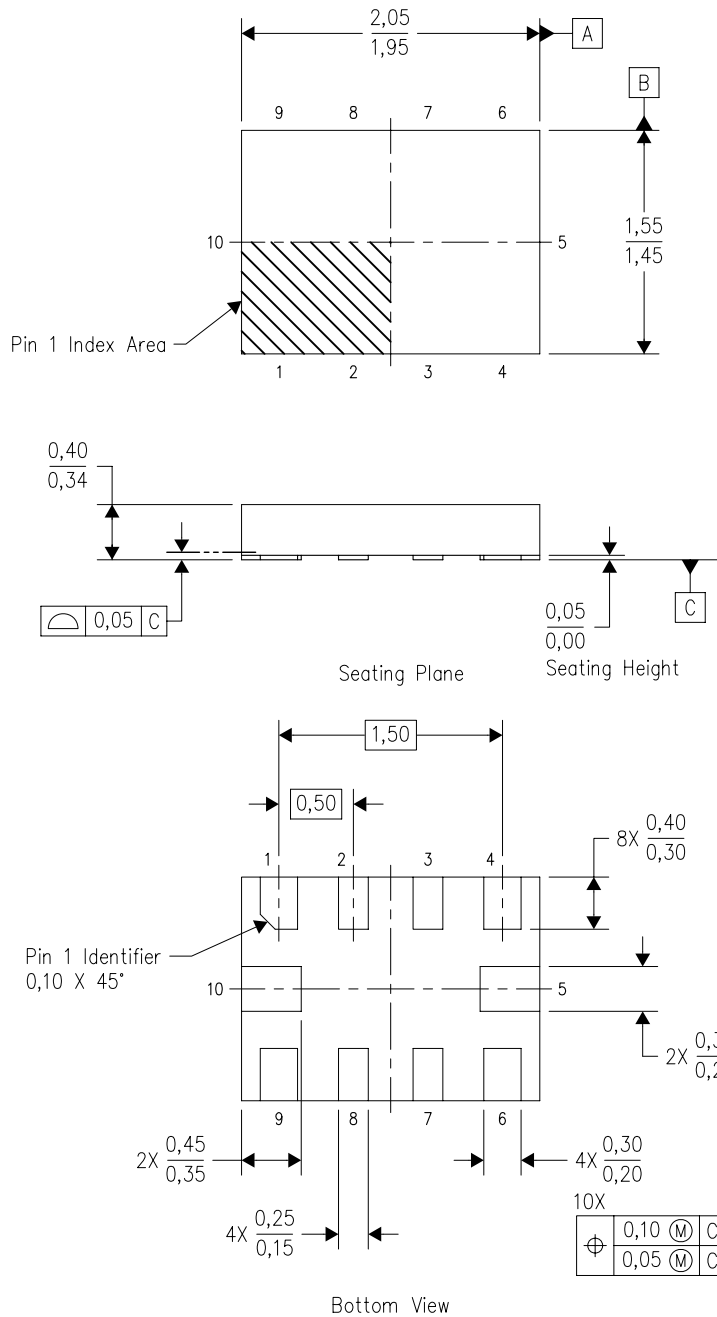

4208528-3/B 04/2008

- NOTES:
- A. All linear dimensions are in millimeters. Dimensioning and tolerancing per ASME Y14.5M-1994.
  - B. This drawing is subject to change without notice.
  - C. QFN (Quad Flatpack No-Lead) package configuration.
  - D. This package complies to JEDEC MO-288 variation X2EFD.

RUG (R-PQFP-N10)

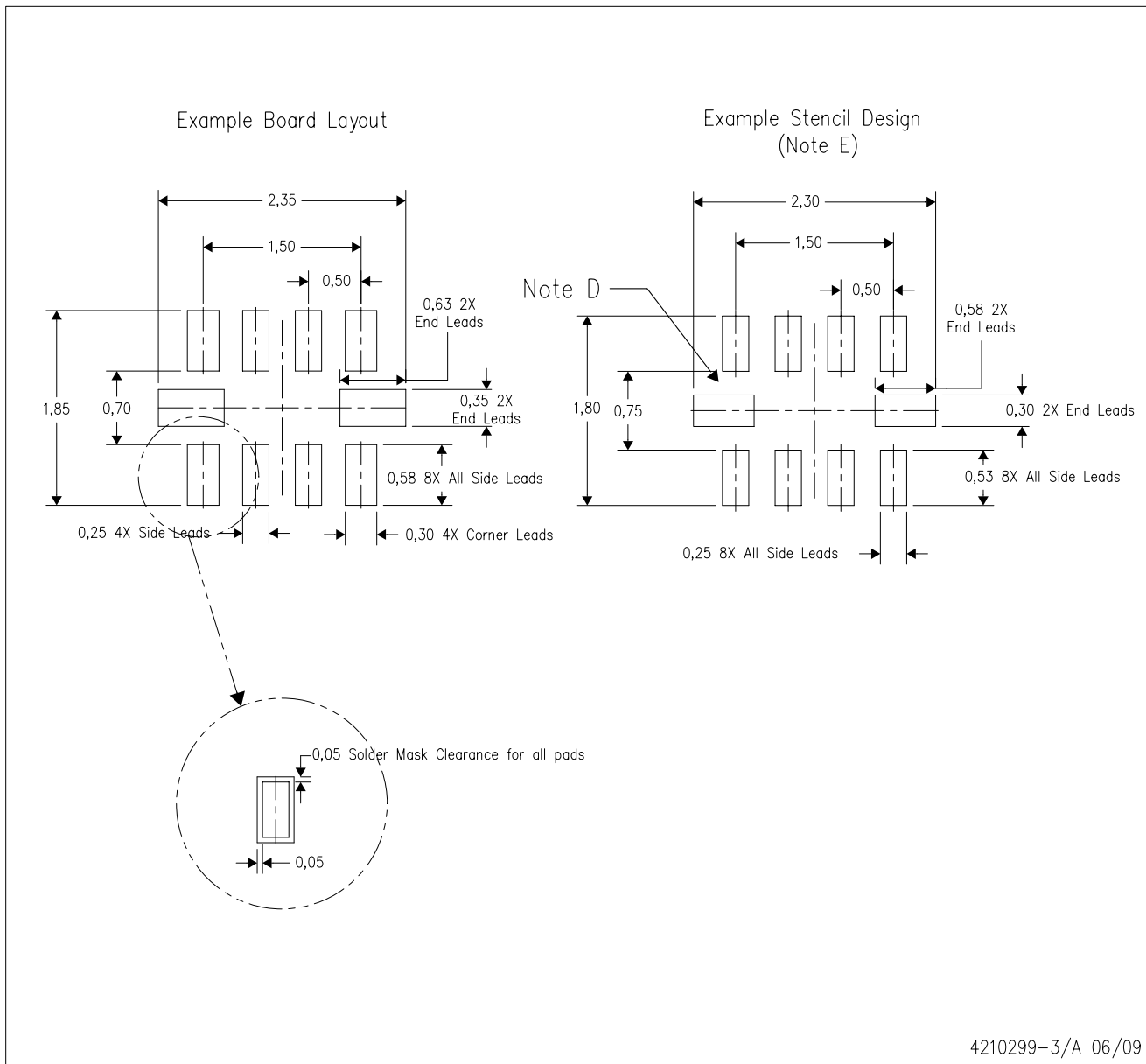

4210299-3/A 06/09

- NOTES:
- A. All linear dimensions are in millimeters.
  - B. This drawing is subject to change without notice.
  - C. Publication IPC-7351 is recommended for alternate designs.
  - D. Customers should contact their board fabrication site for minimum solder mask web tolerances between signal pads.
  - E. Maximum stencil thickness 0,127 mm (5 mils). All linear dimensions are in millimeters.
  - F. Laser cutting apertures with trapezoidal walls and also rounding corners will offer better paste release. Customers should contact their board assembly site for stencil design recommendations. Refer to IPC 7525 for stencil design considerations.
  - G. Side aperture dimensions over-print land for acceptable area ratio > 0.66. Customer may reduce side aperture dimensions if stencil manufacturing process allows for sufficient release at smaller opening.

## IMPORTANT NOTICE

Texas Instruments Incorporated and its subsidiaries (TI) reserve the right to make corrections, enhancements, improvements and other changes to its semiconductor products and services per JESD46, latest issue, and to discontinue any product or service per JESD48, latest issue. Buyers should obtain the latest relevant information before placing orders and should verify that such information is current and complete. All semiconductor products (also referred to herein as "components") are sold subject to TI's terms and conditions of sale supplied at the time of order acknowledgment.

TI warrants performance of its components to the specifications applicable at the time of sale, in accordance with the warranty in TI's terms and conditions of sale of semiconductor products. Testing and other quality control techniques are used to the extent TI deems necessary to support this warranty. Except where mandated by applicable law, testing of all parameters of each component is not necessarily performed.

TI assumes no liability for applications assistance or the design of Buyers' products. Buyers are responsible for their products and applications using TI components. To minimize the risks associated with Buyers' products and applications, Buyers should provide adequate design and operating safeguards.

TI does not warrant or represent that any license, either express or implied, is granted under any patent right, copyright, mask work right, or other intellectual property right relating to any combination, machine, or process in which TI components or services are used. Information published by TI regarding third-party products or services does not constitute a license to use such products or services or a warranty or endorsement thereof. Use of such information may require a license from a third party under the patents or other intellectual property of the third party, or a license from TI under the patents or other intellectual property of TI.

Reproduction of significant portions of TI information in TI data books or data sheets is permissible only if reproduction is without alteration and is accompanied by all associated warranties, conditions, limitations, and notices. TI is not responsible or liable for such altered documentation. Information of third parties may be subject to additional restrictions.

Resale of TI components or services with statements different from or beyond the parameters stated by TI for that component or service voids all express and any implied warranties for the associated TI component or service and is an unfair and deceptive business practice. TI is not responsible or liable for any such statements.

Buyer acknowledges and agrees that it is solely responsible for compliance with all legal, regulatory and safety-related requirements concerning its products, and any use of TI components in its applications, notwithstanding any applications-related information or support that may be provided by TI. Buyer represents and agrees that it has all the necessary expertise to create and implement safeguards which anticipate dangerous consequences of failures, monitor failures and their consequences, lessen the likelihood of failures that might cause harm and take appropriate remedial actions. Buyer will fully indemnify TI and its representatives against any damages arising out of the use of any TI components in safety-critical applications.

In some cases, TI components may be promoted specifically to facilitate safety-related applications. With such components, TI's goal is to help enable customers to design and create their own end-product solutions that meet applicable functional safety standards and requirements. Nonetheless, such components are subject to these terms.

No TI components are authorized for use in FDA Class III (or similar life-critical medical equipment) unless authorized officers of the parties have executed a special agreement specifically governing such use.

Only those TI components which TI has specifically designated as military grade or "enhanced plastic" are designed and intended for use in military/aerospace applications or environments. Buyer acknowledges and agrees that any military or aerospace use of TI components which have **not** been so designated is solely at the Buyer's risk, and that Buyer is solely responsible for compliance with all legal and regulatory requirements in connection with such use.

TI has specifically designated certain components which meet ISO/TS16949 requirements, mainly for automotive use. Components which have not been so designated are neither designed nor intended for automotive use; and TI will not be responsible for any failure of such components to meet such requirements.

### Products

Audio	<a href="http://www.ti.com/audio">www.ti.com/audio</a>
Amplifiers	<a href="http://amplifier.ti.com">amplifier.ti.com</a>
Data Converters	<a href="http://dataconverter.ti.com">dataconverter.ti.com</a>
DLP® Products	<a href="http://www.dlp.com">www.dlp.com</a>
DSP	<a href="http://dsp.ti.com">dsp.ti.com</a>
Clocks and Timers	<a href="http://www.ti.com/clocks">www.ti.com/clocks</a>
Interface	<a href="http://interface.ti.com">interface.ti.com</a>
Logic	<a href="http://logic.ti.com">logic.ti.com</a>
Power Mgmt	<a href="http://power.ti.com">power.ti.com</a>
Microcontrollers	<a href="http://microcontroller.ti.com">microcontroller.ti.com</a>
RFID	<a href="http://www.ti-rfid.com">www.ti-rfid.com</a>
OMAP Applications Processors	<a href="http://www.ti.com/omap">www.ti.com/omap</a>
Wireless Connectivity	<a href="http://www.ti.com/wirelessconnectivity">www.ti.com/wirelessconnectivity</a>

### Applications

Automotive and Transportation	<a href="http://www.ti.com/automotive">www.ti.com/automotive</a>
Communications and Telecom	<a href="http://www.ti.com/communications">www.ti.com/communications</a>
Computers and Peripherals	<a href="http://www.ti.com/computers">www.ti.com/computers</a>
Consumer Electronics	<a href="http://www.ti.com/consumer-apps">www.ti.com/consumer-apps</a>
Energy and Lighting	<a href="http://www.ti.com/energy">www.ti.com/energy</a>
Industrial	<a href="http://www.ti.com/industrial">www.ti.com/industrial</a>
Medical	<a href="http://www.ti.com/medical">www.ti.com/medical</a>
Security	<a href="http://www.ti.com/security">www.ti.com/security</a>
Space, Avionics and Defense	<a href="http://www.ti.com/space-avionics-defense">www.ti.com/space-avionics-defense</a>
Video and Imaging	<a href="http://www.ti.com/video">www.ti.com/video</a>

### TI E2E Community

[e2e.ti.com](http://e2e.ti.com)